

Leica CM1860/CM1860 UV

Cryostat



Instructions for Use
English

Order No.: 14 0491 8U101 - Revision W

Always keep this manual with the instrument.
Read carefully before working with the instrument.

CE

The information, numerical data, notes and value judgments contained in this Instructions for Use represent the current state of scientific knowledge and state-of-the-art technology as we understand it following thorough investigation in this field.

We are under no obligation to update the present Instructions for Use periodically and on an ongoing basis according to the latest technical developments, nor to provide our customers with additional copies, updates etc. of this Instructions for Use.

To the extent permitted in accordance with the national legal system as applicable in each individual case, we shall not be held liable for erroneous statements, drawings, technical illustrations etc. contained in this Instructions for Use. In particular, no liability whatsoever is accepted for any financial loss or consequential damage caused by or related to compliance with statements or other information in this Instructions for Use.

Statements, drawings, illustrations and other information regarding the contents or technical details of the present Instructions for Use are not to be considered warranted characteristics of our products.

These are determined only by the contract provisions agreed between ourselves and our customers.

Leica reserves the right to change technical specifications as well as manufacturing processes without prior notice. Only in this way is it possible to continuously improve the technology and manufacturing techniques used in our products.

This document is protected under copyright laws. All copyrights to this documentation are held by Leica Biosystems Nussloch GmbH.

Any reproduction of text and illustrations (or of any parts thereof) by means of print, photocopy, microfiche, web cam or other methods – including any electronic systems and media – requires express prior permission in writing by Leica Biosystems Nussloch GmbH.

For the instrument serial number and year of manufacture, please refer to the nameplate on the back of the instrument.



Leica Biosystems Nussloch GmbH
Heidelberger Strasse 17 - 19
69226 Nussloch
Germany
Tel.: +49 - (0) 6224 - 143 0
Fax: +49 - (0) 6224 - 143 268
Web: www.LeicaBiosystems.com

Table of contents

1. Important Information	6
1.1 Symbols used in the text and their meaning	6
1.2 Qualification of personnel	11
1.3 Intended purpose	11
1.4 Instrument type	11
2. Safety	12
2.1 Safety Notes	12
2.2 Warnings	13
2.3 Safety devices	13
2.3.1 Locking/unlocking the handwheel	13
2.3.2 Safety guard	14
2.4 Operating Conditions	14
2.5 Operating the instrument	15
2.6 Cleaning and disinfection	16
2.7 Removing the microtome	16
2.8 Maintenance	16
2.8.1 Cleaning up a broken UVC lamp	17
3. Technical Data	18
4. Installing the Instrument	21
4.1 Installation site requirements	21
4.2 Unpacking instructions for the Leica CM1860/CM1860 UV cryostat	22
4.3 Standard delivery - packing list	24
4.4 Installing the handwheel	25
5. Instrument Setup	27
5.1 Electrical connection	27
5.2 Preparations for starting up the instrument	27
5.3 General overview of the Leica CM1860/CM1860 UV	29
5.4 Power switch and circuit breaker	31
5.5 Switching on the instrument	31
6. Operating the Instrument	32
6.1 Control panel 1	32
6.2 Configuring the desired values	34
6.2.1 Setting the time	34
6.2.2 Setting the automatic defrost time (cryochamber)	34
6.2.3 Programming the temperature of the cryochamber	35
6.2.4 Activating the Peltier element	35
6.2.5 Manual defrosting of the quick freeze shelf	36
6.2.6 Manual defrosting of the cryochamber	37
6.2.7 Setting the section thickness	37
6.3 Retraction	38
6.4 Display lock	38
6.5 Control panel 2 – Electric coarse feed	39

7.	Daily Use of the Instrument	40
7.1	The sectioning process	40
7.2	Specimen freezing	40
7.2.1	Quick-freeze shelf	40
7.3	Specimen discs	41
7.3.1	Inserting the specimen discs into the specimen head	41
7.3.2	Specimen orientation	42
7.4	Sectioning	42
7.4.1	Inserting the blade/knife holder base	42
7.4.2	Clearance angle adjustment	44
7.4.3	Premium blade holder	45
7.4.4	Blade holder CE	45
7.4.5	Blade holder CE-TC	51
7.4.6	Knife holder CN.....	52
7.4.7	Cleaning the blade and knife holders.....	56
7.5	Temperature selection chart (in minus °C).....	59
7.6	Defrosting	60
7.6.1	Automatic defrosting of the cryochamber	60
7.6.2	Manual defrosting of the cryochamber.....	60
7.6.3	Manual defrosting of the quick freeze shelf.....	61
7.7	Ending work.....	61
7.7.1	Finishing the daily routine.....	61
7.7.2	Switching off the instrument for a longer period	62
8.	Troubleshooting	63
8.1	Error messages in the display.....	63
8.2	Temperature control button	63
8.3	Possible sources of error, causes and remedies	65
8.3.1	Changing the battery	68
9.	Cleaning, Disinfection, Maintenance.....	69
9.1	Cleaning.....	69
9.2	Disinfection at room temperature.....	69
9.3	Maintenance.....	70
9.3.1	General maintenance instructions.....	70
9.3.2	Replacing the fuses	72
9.3.3	Replacement of the UVC lamp	73
9.3.4	Replacing the LED illumination	76
10.	Ordering Information, Components and Consumables.....	77
10.1	Ordering information.....	77
10.2	Mobile heat extractor - application.....	100
10.3	Cold extraction - using the Thermal block.....	101
10.4	Stationary heat extractor (optional) - application	102
10.5	Installing the shelf (movable) (optional).....	102
11.	Warranty and Service	103
12.	Decontamination Certificate.....	104

1. Important Information

1.1 Symbols used in the text and their meaning



Warning

Leica Biosystems Nussloch GmbH assumes no liability for consequential loss or damage due to failure to observe the following instructions, particularly in relation to transportation and package handling, and failure to observe the instructions for handling the instrument carefully.

Symbol:



Title of the symbol:

Hazard warning

Description:

Warnings are displayed in a white field with an orange title bar and are marked by a warning triangle.

Symbol:



Title of the symbol:

Note

Description:

Notes, i.e. important information for the user, are displayed in a white field with a blue title bar and are marked by a notification symbol.

Symbol:

→ "Fig. 7 - 1"

Title of the symbol:

Item number

Description:

Item numbers for numbering illustrations. Numbers in red refer to item numbers in illustrations.

Symbol:

Power switch

Title of the symbol:

Buttons and switches on the instrument

Description:

Buttons and switches on the instrument that are supposed to be pressed by the user in various situations are displayed as bold, gray text.

Symbol:

Save

Title of the symbol:

Function key

Description:

Software symbols that have to be pressed on the display or information that is output on the display are displayed as bold, gray text.

Symbol:



Title of the symbol:

Notice

Description:

Indicates the need for the user to consult the Instructions for Use for important cautionary information such as warnings and precautions that cannot, for a variety of reasons, be presented on the medical device itself.

Symbol:



Title of the symbol:

Warning, biological hazard

Description:

Instrument parts close to this symbol may be contaminated with substances that pose a threat to health. Avoid direct contact or use appropriate protective clothing.

Symbol:



Title of the symbol:

Warning, low temperature / freezing conditions

Description:

Instrument parts close to this symbol are exposed to low temperatures / freezing conditions that pose a threat to health. Avoid direct contact or use appropriate protective clothing, e.g. frost protection gloves.

Symbol:



Title of the symbol:

Description:

Caution: UVC radiation!

Parts near this label emit ultraviolet radiation when UVC light is turned on. Avoid any unprotected contact.

Symbol:



Title of the symbol:

Description:

Caution: UVC lamp contains Mercury

The UVC lamp contains mercury, which poses a health hazard when released. Any damaged UVC lamp needs to be replaced immediately. Further safety measures apply. Follow the instructions in (→ P. 17 – Replacement of the UVC lamp) and (→ P. 17 – 2.8.1 Cleaning up a broken UVC lamp) if a UVC lamp is damaged or even broken. Also follow the instructions of the manufacturer of the UVC lamp.

Symbol:



Title of the symbol:

Description:

Warning – Hot surface

Warns of a hot surface in normal and single fault conditions of evaporator and condenser.

Symbol:



Title of the symbol:

Description:

Manufacturer

Indicates the manufacturer of the medical device.

Symbol:



Title of the symbol:

Description:

Date of Manufacture

Indicates the date when the medical device was manufactured.

Symbol:



Title of the symbol:

Description:

CE Label

The CE marking is the manufacturer's declaration that the medical product meets the requirements of the applicable EC directives and regulations.

Symbol:



Title of the symbol:

Description:

UKCA Label

The UKCA (UK Conformity Assessed) marking is a new UK product marking that is used for goods being placed on the market in Great Britain (England, Wales and Scotland). It covers most goods which previously required the CE marking.

Symbol:

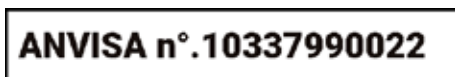

















Title of the symbol:

Description:

ANVISA Identification number

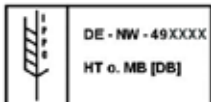
The National Health Surveillance Agency (Agência Nacional de Vigilância Sanitária – ANVISA) is responsible for the registration of medical devices in Brazil and assigns a unique 11-digit identification number to each device, according to specific resolutions.

Symbol: 	Title of the symbol: Description:	In vitro diagnostic medical device Indicates a medical device that is intended to be used as an in vitro diagnostic medical device.
Symbol: 	Title of the symbol: Description:	China RoHS Environmental protection symbol of the China ROHS directive. The number in the symbol indicates the "Environment-friendly Use Period" of the product in years. The symbol is used if a substance restricted in China is used in excess of the maximum permitted limit.
Symbol: 	Title of the symbol: Description:	CSA test symbol (USA/Canada) The CSA test symbol means that a product has been tested and fulfills the applicable safety and/or performance standards, including the relevant standards defined or administered by the American National Standards Institute (ANSI), Underwriters Laboratories (UL), the Canadian Standards Association (CSA), the National Sanitation Foundation International (NSF) and others.
Symbol: 	Title of the symbol: Description:	Country of Origin The Country of Origin box defines the country where the final character transformation of the product has been performed.
Symbol: 	Title of the symbol: Description:	WEEE symbol The WEEE symbol, indicating the separated collection of electrical and electronic equipment wastes, consists of the crossed-out wheeled bin (§ 7 ElektroG).
Symbol: 	Title of the symbol:	Alternating current
Symbol: 	Title of the symbol: Description:	Article number Indicates the manufacturer's catalog number so that the medical device can be identified.
Symbol: 	Title of the symbol: Description:	Serial number Indicates the manufacturer's serial number so that a specific medical device can be identified.
Symbol: 	Title of the symbol: Description:	Consult Instructions for Use Indicates the need for the user to consult the Instructions for Use.

Symbol: 	Title of the symbol: Leica Microsystems (UK) Limited Larch House, Woodlands Business Park, Milton Keynes England, United Kingdom, MK14 6FG	UK Responsible Person
	Description:	The UK Responsible Person acts on behalf of the non-UK manufacturer to carry out specified tasks in relation to the manufacturer's obligations.
Symbol: 	Title of the symbol: Description:	Flammable liquid Package labeling in accordance with German Hazardous Freight Ordinance Road and Rail (GGVSE)/ European Agreement concerning the International Carriage of Dangerous Goods by Road (ADR) for transporting hazardous goods.
		Class 3: FLAMMABLE LIQUID.
Symbol: 	Title of the symbol: Description:	Flammable freezing sprays prohibited This symbol alerts the user that the use of flammable freezing sprays in the cryostat chamber is prohibited due to explosion hazard.
Symbol: 	Title of the symbol: Description:	IPPC symbol The IPPC symbol includes: IPPC symbol
		<ul style="list-style-type: none"> • Country code in accordance with ISO 3166, e.g. DE for Germany • Regional identifier, e.g. NW for North Rhine-Westphalia • Producer/treatment provider code, uniquely assigned number starting with 49 • Treatment method, e.g. HT (heat treatment)
Symbol: 	Title of the symbol: Description:	Do not stack Stacking of the transport packages is not allowed and no load should be placed on the transport packages.
Symbol: 	Title of the symbol: Description:	Fragile, handle with care Indicates a medical device that can be broken or damaged if not handled carefully.
Symbol: 	Title of the symbol: Description:	Keep dry Indicates a medical device that needs to be protected from moisture.

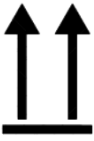
Symbol:**Title of the symbol:**

Upper

Description:

Indicates the correct upright position of the package.

Symbol:

Transport temperature range:

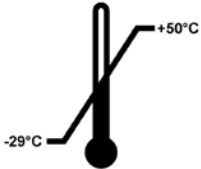
**Title of the symbol:**

Temperature limit for transport

Description:

Indicates the temperature limits for transport to which the medical device can be safely exposed.

Symbol:

Storage temperature range:

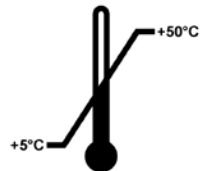
**Title of the symbol:**

Temperature limit for storage

Description:

Indicates the temperature limits for storage to which the medical device can be safely exposed.

Symbol:**Title of the symbol:**

Humidity limitation for storage and transport

Description:

Indicates the storage and transport range of humidity to which the medical device can be safely exposed.

Appearance:**Indication:**

Tilt indicator

Description:

Indicator to monitor whether the shipment has been transported and stored in upright position according to your requirements. With a pitch of 60° or more, the blue quartz sand flows into the arrow-shaped indicator window and sticks there permanently. Improper handling of the shipment is immediately detectable and can be proven definitively.

Symbol:**Title of the symbol:**

Refrigerant

Description:

Designation of the refrigerant used

Symbol:**Title of the symbol:**

Filling weight

Description:

Weight of the refrigerant used

Symbol:**Title of the symbol:**

Maximum operating pressure

Description:

Maximum operating pressure of the refrigeration circuit

1.2 Qualification of personnel

The Leica CM1860/CM1860 UV may only be operated by trained laboratory personnel. Prior to operating the instrument, the operator must carefully read and understand these Instructions for Use and must familiarize him/herself with all technical details of the instrument. The instrument is intended for professional use only.

1.3 Intended purpose

The Leica CM1860/CM1860 UV is a semi-motorized (motorized specimen feeding), high-performance cryostat which is used to freeze and section various human specimen material quickly. These sections are used for histological medical diagnosis by a pathologist, e.g. for cancer diagnosis. The Leica CM1860/CM1860 UV is designed for in vitro diagnostic applications.

Any other use of the instrument is considered improper.

1.4 Instrument type

All information contained in these Instructions for Use applies exclusively to the instrument type indicated on the title page. A nameplate bearing the instrument serial number (SN) is attached to the back of the instrument.

These Instructions for Use include important instructions and information related to the operating safety and maintenance of the instrument. The Instructions for Use are an important part of the product, and must be read carefully prior to startup and use and must always be kept near the instrument.

If additional requirements on accident prevention and environmental protection apply in the country of operation, these Instructions for Use must be supplemented by appropriate instructions to ensure compliance with such requirements.

Proper and intended use includes the observance of all instructions in the Instructions for Use and compliance with all inspection and maintenance instructions.

2. Safety

2.1 Safety Notes



Warning

The safety and caution notes in this chapter must be observed at all times. Be sure to read these notes even if you are already familiar with the operation and use of other Leica products.

These Instructions for Use include important instructions and information related to the operating safety and maintenance of the instrument.

The Instructions for Use are an important part of the product, must be read carefully prior to startup and use and must always be kept near the instrument.

This instrument has been built and tested in accordance with the safety requirements for electrical equipment for measurement, control and laboratory use.

Residual risks

The instrument has been designed and constructed with the latest state-of-the-art technology and according to recognized standards and regulations with regard to safety technology. Operating or handling the instrument incorrectly can place the user or other personnel at risk of injury or can cause damage to the instrument or other property. The machine may be used only as intended and only if all of its safety features are in proper working condition. Malfunctions that impair safety must be remedied immediately.

To maintain this condition and ensure safe operation, the user must observe all notes and warnings contained in these Instructions for Use.

Only original spare parts and permitted original accessories may be used.



Note

These Instructions for Use must be appropriately supplemented as required by the existing regulations on accident prevention and environmental safety in the operator's country.



Warning

- The protective devices on both instrument and components must neither be removed nor modified. Only service personnel qualified by Leica may repair the instrument and access the instrument's internal components.
- Due to explosion hazard, the use of flammable freezing sprays inside the cryostat chamber, while the instrument is turned on, is prohibited.

2.2 Warnings

The safety devices installed in this instrument by the manufacturer only constitute the basis for accident prevention. Operating the instrument safely is, above all, the responsibility of the owner, as well as the designated personnel who operate, service or repair the instrument.

To ensure trouble-free operation of the instrument, make sure to comply with the following instructions and warnings.

2.3 Safety devices

The instrument is equipped with the following safety devices: Handwheel lock and safety guard on the knife holder.



Warning

CM1860 UV only: To prevent adverse health effects from UVC radiation, the UVC lamp cycle can be started only after the sliding window has been properly closed. Closing the window activates the corresponding safety features.

The consistent use of these safety features and strict observation of the warnings and cautions in these Instructions for Use will safeguard the operator by and large from accidents and/or personal injury.

Personal safety precautions



Warning

When working with cryostats, personal safety precautions must always be taken. The wearing of work safety shoes, safety gloves, laboratory coat, mask and safety goggles is mandatory. Chemical disinfection can never be used as a substitute for manual protection in accordance with laboratory regulations.



Note

For current information about certificates and recommendations, visit:
<http://www.LeicaBiosystems.com>

2.3.1 Locking/unlocking the handwheel



Warning

Rotate the handwheel only if the cryostat is cooled and the cryochamber is cold.



Warning

Always lock the handwheel prior to manipulating the knife and specimen, changing the specimen or taking a break.

2 Safety

To lock the handwheel, move its handle to the 12 o'clock (→ Fig. 1-1) or 6 o'clock (→ Fig. 1-2) position. Press the lever (→ Fig. 2-1) fully outward; gently rock the handwheel back and forth until the locking mechanism clicks into place noticeably.

To release the handwheel, press the lever (→ Fig. 2-2) on the handwheel towards the cryostat housing.

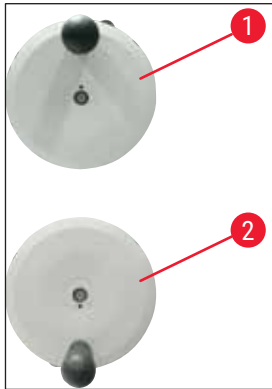

Fig. 1

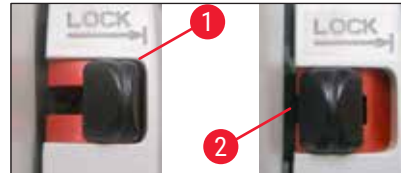

Fig. 2

2.3.2 Safety guard



Warning

Prior to manipulating the knife and specimen, changing the specimen or taking a break, always lock the handwheel and cover the cutting edge with the safety guard.

The knife holder CN and the premium blade holder feature safety guards; the glass anti-roll plate of the CE and CE-TC blade holders also serves as a safety guard.

2.4 Operating Conditions

Transport and installation

- After transporting, do not turn the instrument on for a minimum of 4 hours.
- A waiting period is necessary to allow the compressor oil, which may have been displaced during transport, to return to its original position. Failure to comply with this may cause damage to the instrument.
- The instrument may not be operated in hazardous locations!
- To ensure proper functioning of the instrument, it must be set up while maintaining a minimum distance on all sides from walls and furniture:

- rear:	15 cm
- right:	30 cm
- left:	15 cm.

Electrical connection

- Before connecting the instrument to an AC power outlet, ensure that the AC power of your laboratory matches the values on the nameplate of the instrument!
- The minimum rated voltage must be maintained during the startup phase of the cooling system - (→ [P. 18 – 3. Technical Data](#))! The compressor draws a starting current between 45 and 50 A. Therefore, the electric circuit at the installation site must be inspected by an electrician to ensure that it meets the requirements for a smooth operation of the instrument. A stable power supply in accordance with the instrument's specifications is essential to its proper functioning. Failure to comply with the above can damage the instrument.
- No additional extension cord may be used.

Defrosting



Warning

The quick freeze shelf can become very hot during the defrosting process! Therefore, do not touch it!

2.5 Operating the instrument

- Take care when handling microtome knives and disposable blades. The cutting edge is extremely sharp and can cause serious injuries!



Warning

We strongly recommend using the safety gloves included in (→ [P. 24 – 4.3 Standard delivery - packing list](#))!

- Before leaving the instrument or taking it out of operation, always remove the knife/blade from the knife/blade holder and do not leave open knives/blades lying around after removal!
- Never place a knife on a table with the cutting edge facing upward!
- Never try to catch a falling knife/blade!
- Always clamp the specimen first, then the knife/blade!
- Before handling the specimen or the knife/blade, changing the specimen or taking a break, lock the handwheel and ensure that the knife/blade is covered by the safety guard.
- Extended skin contact with the cold parts of the instrument may cause freezer burns!
- To make sure that the condensation water stemming from the defrost cycles drains into the waste container and to avoid the risk of possible contamination, ensure that the tap of the waste container (→ [Fig. 55-1](#)) is open whenever operating the cryostat. Only shut the tap when draining the waste container!
- Avoid contact with condenser fins as sharp edges may cause personal injury.
- Insertion of any object into condenser fans is to be avoided as this may result in personal injury and/or device damage.
- Wear cut resistant gloves during cleaning.
- In case of visible pollution (such as dust), clean the air inlet opening of the condenser on the bottom right-hand side of the instrument using a brush, broom or vacuum cleaner in the direction of the louvers.

2.6 Cleaning and disinfection

We strongly recommend defrosting the Leica CM1860/CM1860 UV cryostat completely for approx. 24 hours, 1-2x annually or as needed.

- It is not necessary to remove the microtome for routine disinfection.



Note

Remove section waste after **EVERY** change of specimen! Do not start any chemical disinfection until you have done this! Each new specimen is a potential source of contamination. When disinfecting the instrument, take appropriate protective measures (gloves, mask, protective clothing, etc.).



Warning

- Use only alcohol-based disinfectants for disinfecting the cryochamber.
- Do not use any solvents (xylene, acetone, etc.) for cleaning or disinfection.
- Prior to disinfection with alcohol-based disinfectants, switch off the instrument and unplug the power plug.
- When using detergents and disinfectants, observe the specifications of the respective manufacturer.
- Risk of explosion when using alcohol: Provide proper ventilation and ensure the instrument is switched off.
- Risk of icing – Disinfected accessories must be fully dry before reinserting them in the chamber. Do not switch the instrument back on before the cryochamber is fully dry.
- Dispose of waste liquids from disinfection/cleaning as well as of section waste according to applicable regulations on disposal of special category waste!
- Refer to (→ P. 69 – 9.2 Disinfection at room temperature) for information on disinfection at room temperature.
- Ensure that you are following local regulations for disinfection.

After each disinfection, the chamber must be wiped carefully with a cloth and briefly ventilated! Before switching on the instrument again, proper ventilation of the chamber shall be ensured.



Note

Please contact Leica Biosystems for further details on adequate disinfection measures.

2.7 Removing the microtome

- The microtome is encapsulated and therefore does not require removal by the user.

2.8 Maintenance

Replacing the fuses

- Turn the instrument off and disconnect the power plug before replacing the fuses.
- Use only the fuse types specified in (→ P. 18 – 3. Technical Data). Failure to comply with this can cause severe damage to the instrument and its surroundings!

Replacement of the UVC lamp



Note

If both UVC indicator lights are flashing alternately, the UVC lamp must be replaced! (→ P. 73 – 9.3.3 Replacement of the UVC lamp)



- Turn the instrument off and disconnect the power plug before replacing the lamp. For further information, refer to (→ P. 69 – 9. Cleaning, Disinfection, Maintenance).



Warning

It is possible to break the UVC lamp during replacement. If this happens, the lamp change must be completed by Technical Service. The cleanup procedure is described in (→ P. 17 – 2.8.1 Cleaning up a broken UVC lamp).

2.8.1 Cleaning up a broken UVC lamp



Warning

- In case a UVC lamp is broken, open the windows of the working area and leave the room. Let the air clear for 15 to 30 minutes before returning.
- Keep other persons out of the working area until cleanup is completed.
- Do not use a vacuum cleaner to clean up broken UVC lamps. Vacuuming spreads mercury vapor and dust and contaminates the vacuum cleaner.
- Wear protective clothing (cut-resistant gloves, safety goggles) to protect yourself from broken glass and prepare a sealable disposal container (i. e. sealable plastic bag or a glass container with screw cap).

Cleaning up a broken UVC lamp

1. Carefully collect larger pieces of glass and debris using two stiff pieces of paper or cardboard. Pick up smaller pieces and dust using sticky tape.
2. Put all debris and cleanup materials into the prepared disposal container and seal it properly.
3. Mark the container with: **WARNING: MAY CONTAIN MERCURY RESIDUES FROM UVC LAMPS** and store the container outside of the building in a safe place.
4. Finally dispose of the container in accordance with the local applicable disposal regulations.

3 Technical Data

3. Technical Data



Note

Operating temperature range (ambient temperature): 18 °C to 35 °C. All specifications related to temperature of the cooling unit are valid only for an ambient temperature of 22 °C and a relative humidity of not more than 60 %.

Equipment identification

Instrument type	Model numbers 14 0491...
CM1860	...46884
CM1860UV	...46888

Electrical specifications

Nominal voltage ($\pm 10\%$)	120 VAC
Nominal frequency	60 Hz
Power consumption	1440 VA
Power supply	IEC 60320-1 C-20
Max. start-up current for 5 sec.	45 A eff.
Mains input fuse (automatic circuit breaker)	T12A M3
Secondary fuses	F2: T1,6A L250 VAC (6.3x32) F3: T1,0A L250 VAC (6.3x32) F4: T6.25A L250 VAC (6.3x32) F5: T4A L250 VAC (6.3x32)

Dimensions and weight specification

Overall size of device, without handwheel (width x depth x height)	600 x 722 x 1206 mm
Overall size of device, with handwheel (width x depth x height)	730 x 722 x 1206 mm
Working height (armrest)	1025 mm
Overall size of packaging (width x depth x height)	960 x 820 x 1400 mm
Empty weight (without accessories)	135 kg

Environmental specification

Operating altitude	Max. 2000 m above sea level
Operating temperature	+18 °C to +35 °C
Relative humidity (operation)	20 to 60 % RH non-condensing
Transport temperature	-29 °C to +50 °C
Storage temperature	+5 °C to +50 °C

Relative humidity (transport / storage)	10 to 85 % RH non-condensing
Minimum distance to walls	Back: 150 mm Right: 300 mm Left: 150 mm

Emmissions and boundary conditions

Overvoltage category according to IEC 61010-1	II
Pollution degree according to IEC 61010-1	2
Means of protection according to IEC 61010-1	Class 1
Degree of protection according to IEC 60529	IP20
Heat emission	1440 J/s
A-weighted noise level, measured at 1 m distance	< 70 dB (A)
EMC class	B (FCC Rules part 15) B (CISPR 11, IEC 61326, CAN ICES-3 (A)/NMB)



Warning

Observe (→ P. 21 – 4.1 Installation site requirements)!

Chamber cooling

Temperature range	0 °C to -35 °C ±3 K, adjustable in 1 K increments, at ambient temperature of 22 °C
Cooling time to -35 °C	Max. 6 h, at starting point and ambient temperature of 22 °C and 60 % relative humidity
Max. operating pressure	25 bar
Refrigerant*	315 g, refrigerant R-452A*
Defrosting	Hot gas defrosting
Manual defrosting	Yes
Automatic defrosting	Yes
Programmable	Yes (hot gas defrost), selectable time
Defrosting intervals	1 defrost in 24 h or manual hot gas defrost
Defrost duration	12 minutes
Automatic turn-off defrost	At chamber temperature of more than -5 °C At evaporator temperature of more than +38 °C

Quick-freeze shelf

Lowest temperature	-40 °C (+3/-5 K), at chamber temperature of -35 °C and at ambient temperature of 22 °C
Number of freezing stations	8+2
Defrosting	Hot gas defrosting
Defrost duration	12 minutes

3 Technical Data

Automatic turn-off defrost	At chamber temperature of more than -5 °C At evaporator temperature of more than +38 °C
Manual start	Yes
Automatic start	No
Manual abort	Yes
Peltier station / Quick-freeze shelf	
Max. difference in temperature to quick-freeze shelf	Min. 17 K, at chamber temperature of -35 °C
Number of freezing stations	2
Duration of active time	10 minutes (turn-off possible after 6 minutes)
Defrosting	Together with quick-freeze shelf



Warning

*) Refrigerant and compressor oil must be replaced by service personnel qualified and authorized through Leica only.

Microtome

Type	Rotary microtome, encapsulated
Section thickness range	1 µm to 100 µm
Horizontal specimen feed	25 mm +3 mm
Vertical specimen stroke	59 mm ±1 mm
Specimen retraction	20 µm (can be deactivated)
Maximum specimen size	55 mm x 55 mm or 50 mm x 80 mm
Specimen orientation	±8 ° (x-, y-axis)
Coarse feed	Slow: max. 600 µm/s Fast: min. 900 µm/s

UVC lamp (only CM1860UV)

Manual start	Yes
Automatic start	No
Manual abort	Yes
Duration cycle	Short cycle: 30 minutes Long cycle: 180 minutes

4. Installing the Instrument

4.1 Installation site requirements



Warning

Do not operate in rooms with explosion hazard! To ensure proper functioning of the instrument, it must be set up while maintaining a minimum distance on all sides from walls and furniture (→ P. 14 – Transport and installation).

The place of installation must meet the following requirements:

- The instrument requires an installation area of approx. 600 x 730 mm
- Room volume must be at least 8 m³
- Room temperature consistently 18 °C - 35 °C
- Temperature range during storage: 5 °C - 50 °C
- Relative humidity, maximum 60 % (non-condensing)
- Elevation: up to a max. of 2000 m above sea level



Note

Condensation water can form in the instrument if there is an extreme difference in temperature between the storage location and the installation site and if air humidity is high at the same time. In this case, wait at least four hours before switching on the instrument. Failure to comply with this may cause damage to the instrument.

- The instrument is designed for indoor use only.
- The power plug/circuit breaker must be freely and easily accessible. The power socket may not be located further than 2.5 m from the instrument.
- Power supply at a distance no greater than the length of the power cord – an extension cord must **NOT** be used.
- The floor must be vibration-free as far as possible and have sufficient load capacity and rigidity for the weight of the instrument.
- Avoid impacts, direct sunlight and excessive temperature fluctuations.
- The instrument must be connected to a compatible grounded power socket. Use only the power cord provided, which is intended for the local power supply.
- The chemicals to be used for disinfection are both highly flammable and hazardous to health. Therefore the installation location must be well ventilated, and must contain no sources of ignition of any kind.
- Furthermore, this instrument must **NOT** be operated directly under the outlet of an air-conditioning system, since the increased air circulation accelerates icing of the cryochamber.
- The installation location must be protected against electrostatic charge.



Note

Room temperatures and humidity levels in excess of the recommendations above will affect the cryostat's cooling capacity and the lowest stated temperatures will not be reached.

4 Installing the Instrument

4.2 Unpacking instructions for the Leica CM1860/CM1860 UV cryostat



Note

- When the instrument is delivered, check the tilt indicators (→ "Fig. 3") on the packaging.
- If the arrowhead is blue, the shipment was transported laying flat, was tilted at too great an angle or fell over during transport. Note this on the shipping documents and check the shipment for possible damage.
- Two persons are required to unpack the instrument.
- The illustrations serve only as an example to explain the unpacking procedure.



Fig. 3



Warning

Caution when removing the strips (→ Fig. 4-1)! There is a risk of injury when opening them (the strip has sharp edges and is under tension)!

- To remove the strips (→ Fig. 4-1), suitable shears and safety gloves are required.
- Stand next to the packaging and cut through the strips at the locations shown (→ Fig. 4-3).
- Lift up the covering box (→ Fig. 4-2) and remove it.
- Carefully remove the adhesive tape (→ Fig. 5-1) holding the two transport anchors (→ Fig. 5-2) on both sides of the instrument and remove them.
- Then remove the dust cover (→ Fig. 5-3) from the instrument.
- Remove the two white and the two blue transport anchors (→ Fig. 5-4), which protect the cryochamber window.
- Take the accessories (→ Fig. 5-5) out.
- Lift and remove the wooden edge (→ Fig. 6-1).
- Remove the ramp (→ Fig. 5-6) on the front side of the pallet (→ "Fig. 5") and properly insert it into the rear side (→ "Fig. 7").
- Insert the ramp properly. Make sure the ramp components designated "L" (left) and "R" (right) click into place in the provided guide channel (→ Fig. 7-5).
- When correctly installed, the guide rails (→ Fig. 7-6) are located inside and the arrows (→ Fig. 7-7) point toward each other.



Fig. 4



Fig. 5



Fig. 6

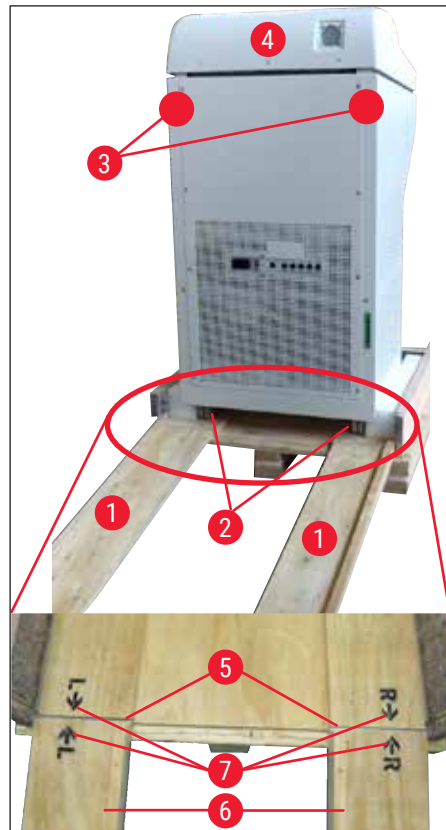

Fig. 7



Warning

Do not slide the instrument by its hood (→ Fig. 7-4) and observe the transport grip points (→ Fig. 7-3). The castors (→ Fig. 7-2) must run over the ramp (→ Fig. 7-1) at the front and rear. Risk of tipping! The instrument must be transported in an upright position.

4 Installing the Instrument

- Carefully roll the instrument backwards over the ramp from the pallet (→ Fig. 7-2) and slide it on the castors to the installation location.

Transport to the site

- Check if the location meets the requirements specified in the (→ P. 21 – 4.1 Installation site requirements).
- Transport the instrument to the desired location and observe the following notes:



Warning

- The instrument must be transported in either an upright position or slightly tilted (max. 30 °).
- When tilting the instrument 2 people must counterbalance from the front side as the instrument can tip over and cause severe injury, as well as severe damage to the instrument and the surrounding area!

- When transporting the instrument on the castors (→ Fig. 8-2), grip the instrument only at the marked housing locations (→ Fig. 8-3).
- To ensure a secure upright position at its intended location, the instrument must be adjusted. To do so, unscrew both adjusting feet (→ Fig. 8-1) using the provided open-end wrench (size 13) (→ Fig. 8-4).
- When subsequently transporting the instrument any further on castors, screw them back in all the way.

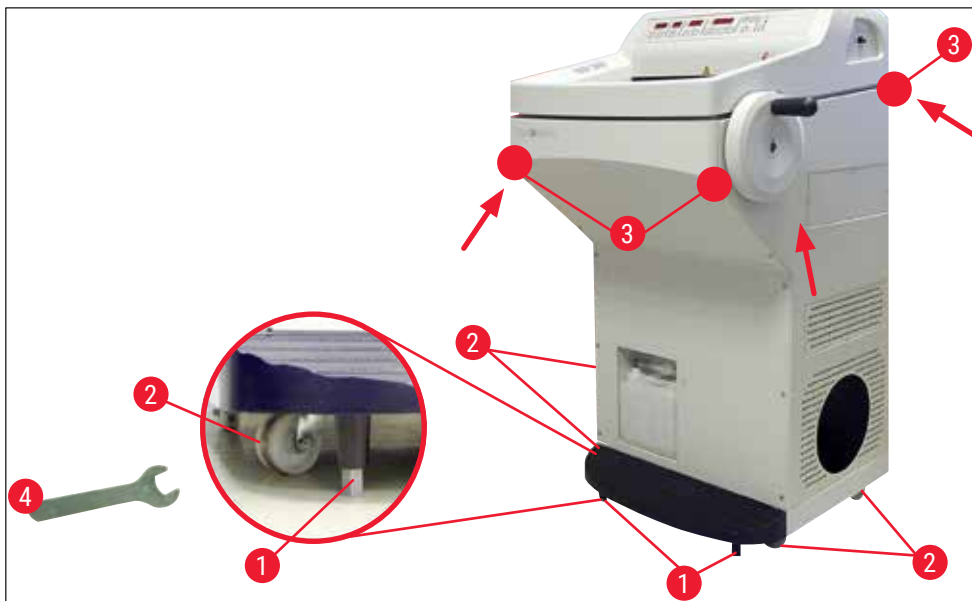

Fig. 8

4.3 Standard delivery - packing list

Qty	Designation	Order No.:
1	Basic instrument in the respective voltage variant (local power cord included)	
1	Handwheel with marking	14 0477 41346
1	Specimen disc set, consisting of:	14 0470 43550
4	Specimen discs, 25 mm	14 0416 19275

Qty	Designation	Order No.:
4	Specimen discs, 30 mm	14 0370 08587
1	Section waste tray	14 0471 30787
1	Storage shelf, right	14 0491 46599
1	Storage shelf, left	14 0491 46598
1	Brush shelf	14 0491 46984
1	Freeze shelf cover	14 0491 46873
1	Rubber plug	14 3000 00148
1	Toolset, consisting of:	14 0436 43463
1	Brush, fine	14 0183 28642
1	"Leica" brush with magnet	14 0183 40426
1	Hexagon key, size 1.5	14 0222 10050
1	Hexagon key, size 2.5	14 0222 04137
1	Hexagon key, size 3.0	14 0222 04138
1	Hexagon key, size 4.0	14 0222 04139
1	Hexagon key with ball head, size 4.0	14 0222 32131
1	Hexagon key, size 5.0	14 0222 04140
1	Key with handle, size 5.0	14 0194 04760
1	Hexagon key, size 6.0	14 0222 04141
1	Double-head wrench, sizes 13/16	14 0330 18595
1	Bottle of cryo oil, 50 ml	14 0336 06098
1	Bottle of embedding medium for freeze sectioning, tissue freezing medium, 125 ml	14 0201 08926
1	A pair of cut-resistant gloves, size M	14 0340 29011
1	Canada / USA bundle of Instructions for Use (incl. English printout and additional data storage device 14 0491 8U200)	14 0491 8U001

Compare the delivered components with the parts list and your order. Should you find any discrepancies, please contact your Leica sales office without delay.

If the supplied local power cord is defective or lost, please contact your local Leica representative.



Note

A choice of different knife holders is available for the Leica CM1860/CM1860 UV.

4.4 Installing the handwheel



Note

The handwheel and all parts for the assembly can be found in the carton with the accessories. The handwheel can be dismounted for transporting (e.g. narrow doors).

4 Installing the Instrument



Fig. 9

To install the handwheel, follow these steps:

1. Insert the pin (→ Fig. 9-1) of the handwheel shaft into the hole (→ Fig. 9-2) of the handwheel.
2. Attach the spring washer (→ Fig. 9-3) to the screw as shown in (→ "Fig. 9") (→ Fig. 9-4).
3. Tighten the screw (→ Fig. 9-4) using the Hexagon key (6 mm).
4. Attach the cover disk (self-adhesive - not pictured).

» To deinstall, proceed in reverse order.



Warning

Rotate the handwheel only if the cryostat is cooled and the cryochamber is cold.

5. Instrument Setup

5.1 Electrical connection



Note

- The minimum rated voltage must be maintained during the startup phase of the cooling system (→ P. 18 – 3. Technical Data)!
- The compressor draws a starting current between 45 and 50 A.
- Therefore, the electric circuit at the installation site must be inspected by an electrician to ensure that it meets the requirements for a smooth operation of the instrument.
- A stable power supply in accordance with the instrument's specifications is essential to its proper functioning. Failure to comply with the above can damage the instrument.

- Have separate fuse protection provided for the electric circuit.
- Do not connect any other devices to this electric circuit.
- The instrument is de-energized when the power cord is disconnected from the power supply (power supply circuit breaker).

5.2 Preparations for starting up the instrument

- Check that the power supply voltage and power frequency in your laboratory match the values on the nameplate of the instrument.



Warning

Use only the power cord provided by Leica. Failure to observe this causes an imminently hazardous situation that may result in death or serious injury to the operator or other personnel.

- Check that the rubber plug is tight (in the drain hole below the left storage shelf), and press it tightly into the drain if necessary.



Note

The rubber plug must be tight in the instrument while work is being carried out in the cryostat. Remove the plug only when instrument is switched off (not during daily defrost!).

- Place the storage shelves in the cryochamber.
- Insert the section waste tray and brush shelf.
- Install the movable shelf (optional) (→ P. 102 – 10.5 Installing the shelf (movable) (optional)).
- Install the stationary heat extractor (optional) (→ P. 102 – 10.4 Stationary heat extractor (optional) - application).
- Place the knife holder base on the microtome base plate and clamp it.
- Set and clamp the blade or knife holder in place (→ P. 42 – 7.4 Sectioning).
- Open the knife case with the knife and place it in the cryochamber for pre-cooling.
- Place all tools needed for specimen preparation in the cryochamber.
- Close the sliding window.
- Plug the power plug into the power socket.

**Warning**

We do not recommend placing disposable blade dispensers in the cryochamber for pre-cooling because it is possible that individual blades may be stuck together during removal. They pose a risk of injury!

5.3 General overview of the Leica CM1860/CM1860 UV

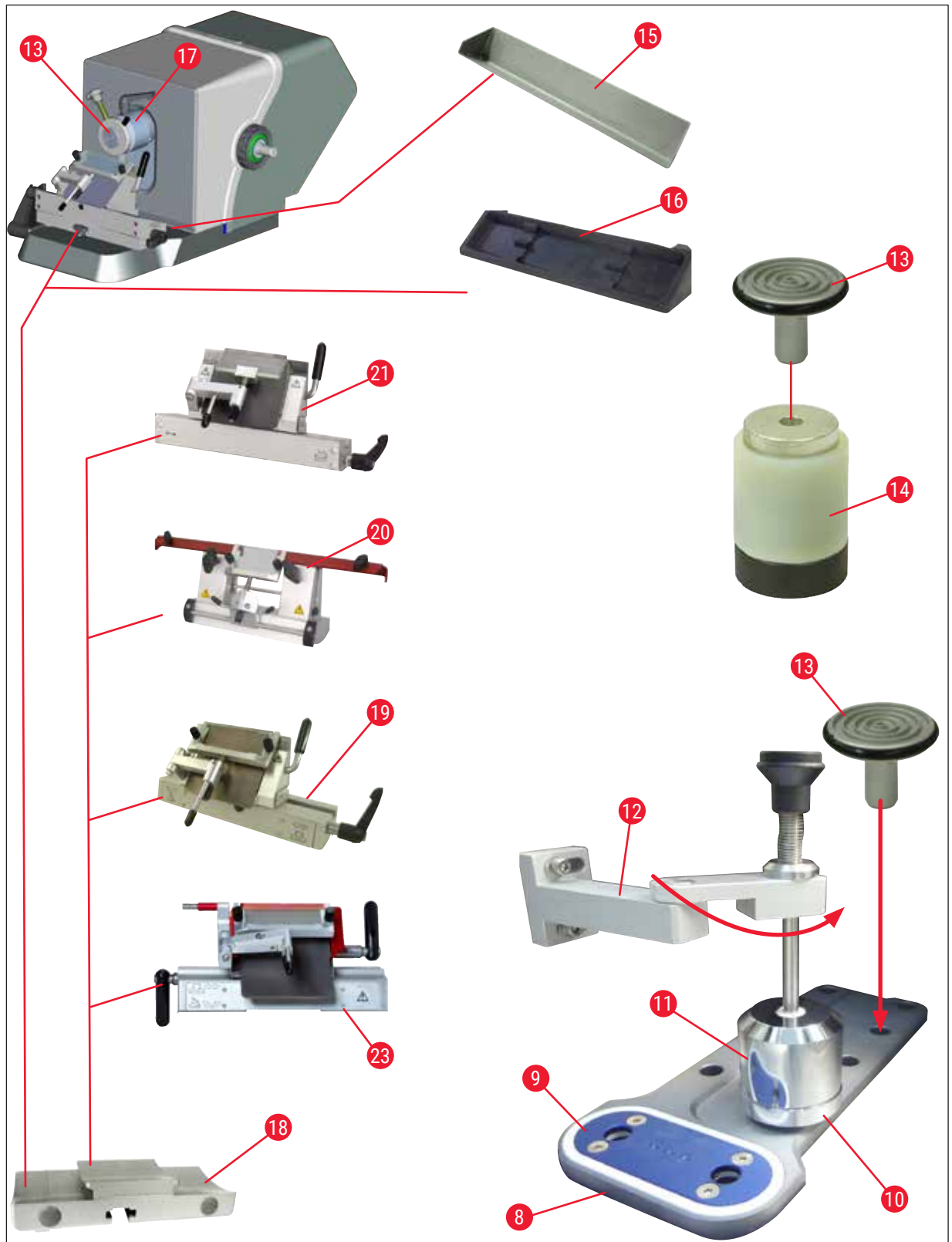

Fig. 10

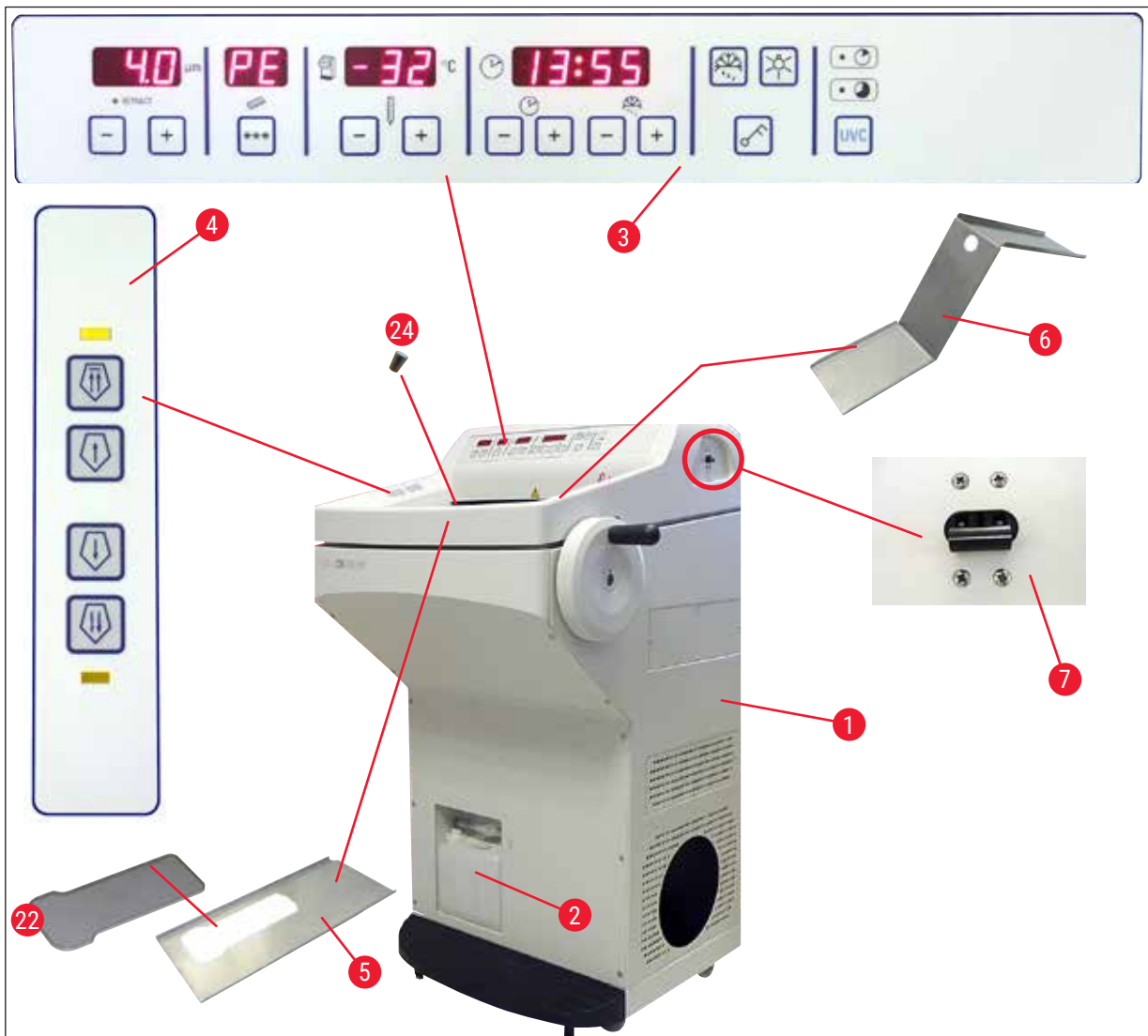

Fig. 11

- | | | | |
|----|---|----|------------------------------------|
| 1 | Leica CM1860/CM1860 UV | 13 | Specimen disc |
| 2 | Waste container | 14 | Thermal block (optional) |
| 3 | Control panel 1 | 15 | Section waste tray |
| 4 | Control panel 2 | 16 | Brush shelf |
| 5 | Storage shelf, left | 17 | Orientable specimen head |
| 6 | Storage shelf, right | 18 | Blade/knife holder base (optional) |
| 7 | Automatic fuse and ON/OFF switch | 19 | Blade holder CE (optional) |
| 8 | Quick-freeze shelf | 20 | Knife holder CN (optional) |
| 9 | Peltier element | 21 | Blade holder CE-TC (optional) |
| 10 | Parking station (optional) | 22 | Freeze shelf cover |
| 11 | Stationary heat extractor (optional) | 23 | Premium blade holder |
| 12 | Heat extractor holder (optional) | 24 | Rubber plug |

5.4 Power switch and circuit breaker

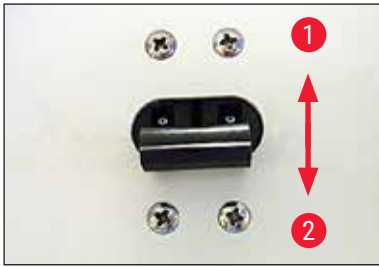

Fig. 12

- The switch must be in the top position (switch position 1) (→ "Fig. 12") for switching on the circuit breaker (→ Fig. 12-1).
- The switch must be in the bottom position (switch position 0) (→ Fig. 12-2) for switching off the circuit breaker.

5.5 Switching on the instrument



Warning

After transporting, wait at least 4 hours before switching the instrument on. This waiting period is necessary to allow the compressor oil, which may have been displaced during transport, to return to its original location. Failure to comply with this may cause damage to the instrument.

The software version "0:40" (shown here (→ "Fig. 13") only as an example) is displayed in the 4-digit LED display for the time. This display disappears after approx. 2 seconds and switches to the display of the instrument type "1860". The standard time is then displayed.



Fig. 13

- Switch the instrument on at the circuit breaker (→ "Fig. 12"). The instrument is now initialized.
- The instrument is factory-configured as follows:

Time:	00:00
Defrost time:	23:45
Chamber cooling:	On (temperature display)
Peltier element:	Off (display PE)
- Program the desired values as described under (→ P. 34 – 6.2.1 Setting the time) to (→ P. 35 – 6.2.3 Programming the temperature of the cryochamber).



Note

In normal operation, a pressure compensation shortly before the compressor starts up might lead to a hissing sound.

6 Operating the Instrument

6. Operating the Instrument

6.1 Control panel 1



Fig. 14

Function keys

Lamp button



ON/OFF switch for cryochamber illumination

Manual defrost button



For switching the manual defrost on and off

Key button



To lock and unlock the control panel to protect the entered parameters from unintended modifications. Enable/disable the lock by pressing and holding for 5 seconds.

UVC lamp (CM1860 UV only)



Note

Only CM1860 UV: Before starting a UVC cycle, move the anti-roll guide to the side. Opening the sliding window interrupts the UVC cycle. Press the **UVC** key to resume the UVC cycle.

UVC lamp



Duration - 30 min

Duration - 180 min

To initiate/cease a UVC cycle and/or to acknowledge interruption of a UVC cycle.



Note

For information on the lifetime of and on replacing the UVC lamp, refer to (→ P. 73 – 9.3.3 Replacement of the UVC lamp).

To start the UVC lamp, the sliding window must be completely closed.

- Press the **UVC** button – 1x briefly, 30 min mode
- Press the **UVC** button – 1x (approx. 4 sec.), 180 min mode

Status	LED short UVC cycle	LED long UVC cycle	UVC lamp
Ready ¹	OFF	OFF	OFF
Lifetime expired ²	Flashing in alternation		OFF
Short UVC cycle active	ON	OFF	ON
Long UVC cycle active	OFF	ON	ON
Short UVC cycle aborted ³	Flashing	OFF	OFF
Long UVC cycle aborted ⁴	OFF	Flashing	OFF

¹ Status: Ready

Both LEDs and the UVC lamp are off.

- Start short UVC cycle: Press the **UVC** button briefly (<1 second). The LED for the short UVC cycle will light up.
- Start long UVC cycle: Press the **UVC** button for longer (>1 second). The LED for the short UVC cycle goes out and the LED for the long UVC cycle goes on.

² Status: Lifetime of the UVC lamp expired

- The LEDs for the short and long UVC cycle modes illuminate alternately, and the UVC lamp is off.
- This status is displayed as soon as the lifetime of the UVC lamp (9000 hours) has been reached. For replacing the UVC lamp, refer to ([→ P. 73 – 9.3.3 Replacement of the UVC lamp](#)).



Note

After replacing the UVC lamp, its lifetime counter must be reset. To do so, press and hold the **UVC** button for longer than 30 seconds. The counter has been reset successfully if the LED for the long UVC cycle goes out while the button is being pressed. Once the **UVC** button is released, the UVC cycle status goes into ready mode.

³ Status: Short UVC cycle aborted

The LED for short UVC cycle flashes, and the UVC lamp is off. The operator must press the **UVC** button to confirm. The UVC cycle system goes into ready mode, or, if the lifetime of the UVC lamp has expired, both LEDs flash alternately.

⁴ Status: Long UVC cycle aborted

The LED for long UVC cycle flashes, and the UVC lamp is off. The operator must press the **UVC** button to confirm. The UVC cycle system goes into ready mode, or, if the lifetime of the UVC lamp has expired, both LEDs flash alternately.

6 Operating the Instrument



Note

The UVC cycle mode is aborted as soon as the sliding window of the cryostat is open or the operator presses the **UVC** button. In the case of a power failure, when the instrument restarts it checks whether it was running a UVC cycle, and if so which one. The LED of the determined UVC cycle (short or long UVC cycle) flashes.

6.2 Configuring the desired values

6.2.1 Setting the time



Fig. 15

Use the function button labeled with a clock symbol to set the time of day.

- Set the current time using the **Plus** (→ Fig. 15-1) and **Minus** (→ Fig. 15-2) buttons.
- Pressing and holding the **Plus** or **Minus** button continuously increases or decreases the time (auto-repeat function).

6.2.2 Setting the automatic defrost time (cryochamber)

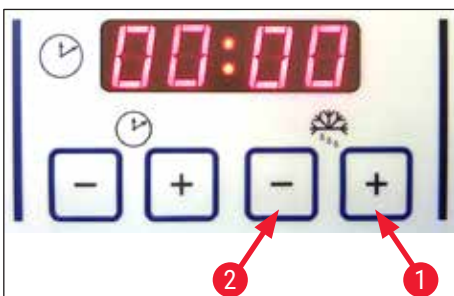

Fig. 16

The automatic defrost cycle takes place once every 24 hours.

- Briefly touch the **Plus** (→ Fig. 16-1) or **Minus** (→ Fig. 16-2) button to display the beginning of the defrost time that is currently set. The two LEDs between the display of hours and minutes flash at the same time.
- To change the beginning of the defrost time in 15-minute increments, touch or press and hold the **Plus** or **Minus** button. The defrost duration is 12 minutes.

6.2.3 Programming the temperature of the cryochamber

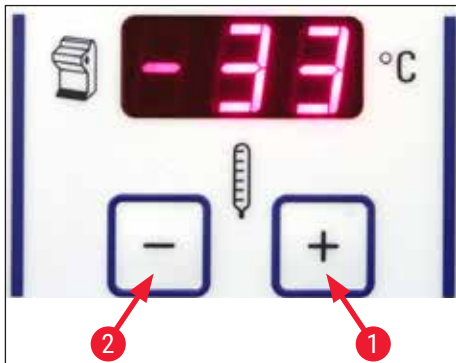

Fig. 17

The temperature of the cryochamber is set and indicated on the panel marked with the cryostat symbol.

- The actual temperature is the standard indication. Briefly touch the **Plus** (→ Fig. 17-1) or **Minus** (→ Fig. 17-2) button to display the target temperature.
- You can now set the desired value using these buttons. Pressing and holding the **Plus** or **Minus** button continuously increases or decreases the cryochamber temperature.
- 5 seconds after finishing the programming the current value will be displayed again.

6.2.4 Activating the Peltier element

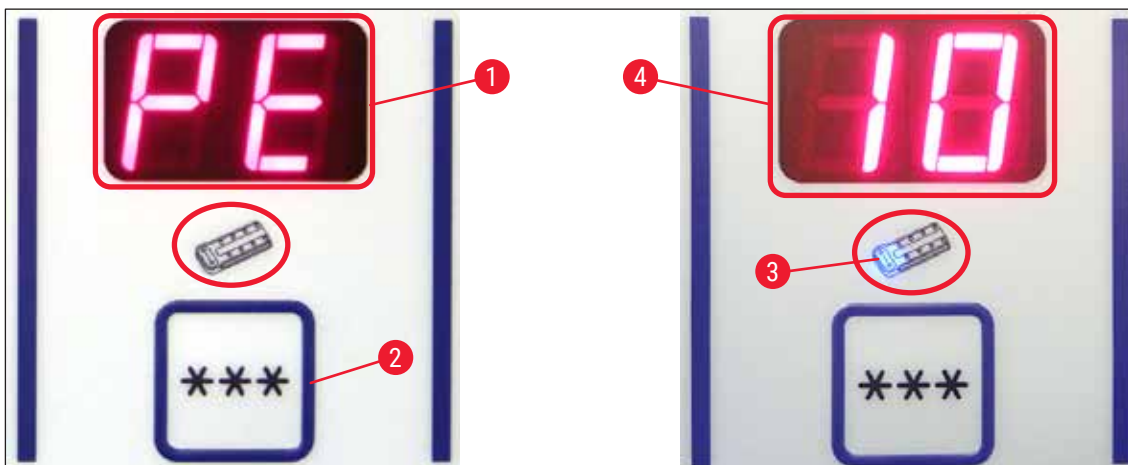

Fig. 18

① The Peltier element provides additional cooling for the freezing stations. Upon activation of the Peltier element, the compressor of the cooling system is started after 40 seconds to reinforce the thermal conductivity effect.

- Display **PE** (= Peltier element) (→ Fig. 18-1).
- Activate it by pressing the ******* key (→ Fig. 18-2).
- If the Peltier element has been activated, a blue LED in the Peltier symbol lights up (→ Fig. 18-3). After the activation, the display switches to the number **10** (→ Fig. 18-4) (the Peltier element now cools for 10 minutes). The remaining cooling time is always shown in the display.
- The Peltier element turns off automatically after 10 minutes.

6 Operating the Instrument

- When only 4 minutes are remaining, a dot (4.) appears after the number 4. From this time on, it is safe to shut off the Peltier element early.
- To shut it off early, press the *** button.
- After the shutoff, the display returns to PE (→ Fig. 18-1).

6.2.5 Manual defrosting of the quick freeze shelf



Warning

The quick freeze shelf can become hot during the defrosting process. Therefore, do not touch it!

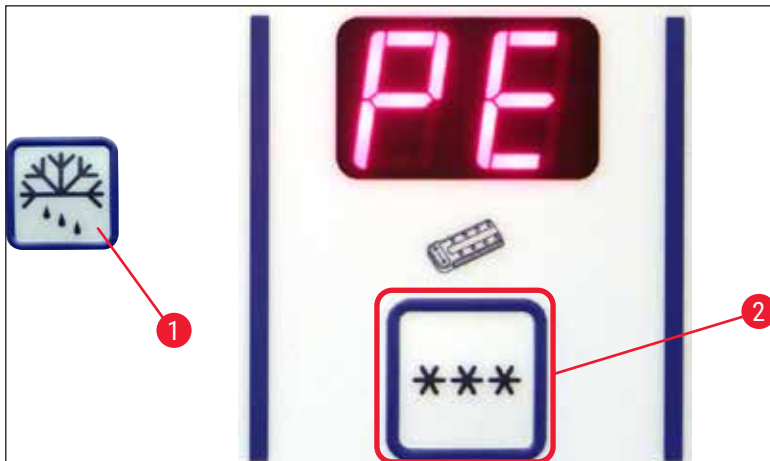

Fig. 19

- You can activate the manual defrost of the quick freeze shelf by pressing the key (→ Fig. 19-1) (continuous tone sounds), followed immediately by the key (→ Fig. 19-2) (continuous tone stops). The display flashes during the defrosting.
- To shut off the manual defrost early, press the (→ Fig. 19-1) key, followed immediately by the (→ Fig. 19-2) key. The quick freeze shelf can become hot during the defrosting process. The defrost duration is 12 minutes.



Note

The quick freeze shelf and cryochamber cannot be defrosted at the same time.

6.2.6 Manual defrosting of the cryochamber

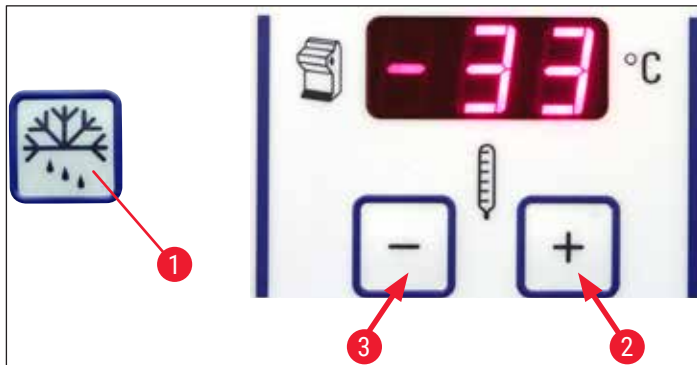

Fig. 20

- You can activate manual defrosting of the cryochamber by pressing the key (→ Fig. 20-1) (continuous tone sounds), followed immediately by the key (→ Fig. 20-2) in the cryochamber temperature selection field (continuous tone stops). The display flashes during the defrosting (duration 12 min.).
- To shut off the manual defrost early, press the (→ Fig. 20-1) key, followed immediately by the (→ Fig. 20-3) key in the cryochamber temperature selection field.

6.2.7 Setting the section thickness

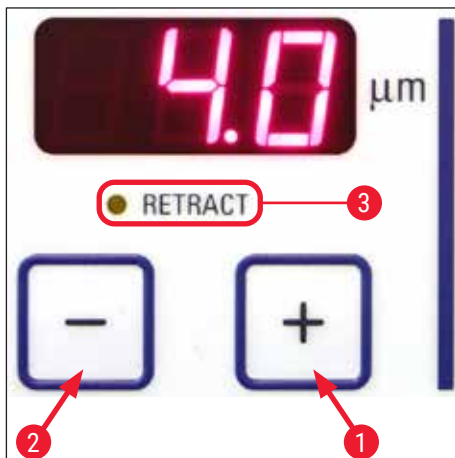

Fig. 21

Adjust the section thickness in a range from 1 - 100 μm using the **Plus** (→ Fig. 21-1) and **Minus** (→ Fig. 21-2) pushbuttons in the upper control panel (→ "Fig. 21"):

1 μm	-	5 μm	in 0.5 μm increments,
5 μm	-	20 μm	in 1 μm increments,
20 μm	-	60 μm	in 5 μm increments,
60 μm	-	100 μm	in 10 μm increments.

The preselected section thickness appears in the display above the keys.

- Start trimming at approx. 20 μm .

6 Operating the Instrument

- Decrease the section thickness continuously until the required thickness is reached.
- After changing the section thickness, discard the first two or three sections.
- For sectioning, turn the handwheel at a constant speed.

6.3 Retraction



Note

The factory default setting for the retraction is **ON!**

Enabling retraction:

When switching on the instrument (in the initialization phase), press the **Plus** button (→ Fig. 21-1). If the handwheel is at the 6 o'clock position or the specimen head is "down", the yellow LED next to **Retract** (→ Fig. 21-3) is illuminated. When the instrument is switched off, this status is stored.

Disabling retraction:

When switching on the instrument (in the initialization phase), press the **Plus** button (→ Fig. 21-2). If the handwheel is at the 6 o'clock position or the specimen head is "down", the yellow LED next to **Retract** (→ Fig. 21-3) is not illuminated and remains off even during sectioning.

6.4 Display lock

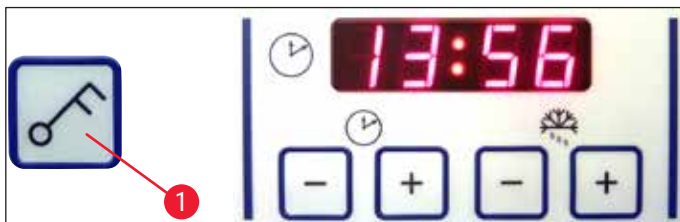

Fig. 22

After the display is locked using the **Key** button (→ Fig. 22-1) (press and hold for 5 sec.), set values can **NO LONGER** be changed.



Note

Only the UVC lamp can still be enabled/disabled by pressing the **UVC** key.

- » To unlock the display, press and hold the **Key** button (→ Fig. 22-1) again for 5 seconds.

When the display is locked, the LEDs between the hour and the minute display on the time panel are turned off (→ "Fig. 22").

6.5 Control panel 2 – Electric coarse feed



Fig. 23

Moving the specimen away from the knife



Fast

- Fast return to the rear end position starts.
The LED (→ Fig. 23-1) flashes while the specimen head is in motion.
The LED lights up when the rear end position has been reached (→ Fig. 23-1).



Slow

- The return movement can be stopped by pressing one of the coarse feed buttons.
- Slow return to the rear end position starts.
The motion continues as long as the button is held.

Advancing the specimen toward the knife



Slow

- Fast or slow feed toward the knife starts.
The LED (→ Fig. 23-2) starts flashing as long as the specimen head is in motion.
The LED lights up when the forward end position has been reached (→ Fig. 23-2).



Fast

To feed the specimen, press and hold the appropriate **Slow** or **Fast** button.

7. Daily Use of the Instrument

7.1 The sectioning process

Preparation

1. Install all necessary parts, whether standard or optional (e.g. panels, waste and brush tray and the selected knife or blade holder). Make sure that they are mounted and cooled.
2. Set the chamber temperature according to the tissue type to be sectioned (→ P. 59 – 7.5 [Temperature selection chart \(in minus °C\)](#)).
3. Freeze specimen onto a specimen disc (→ P. 41 – 7.3 [Specimen discs](#)) and mount it into the specimen head (→ P. 41 – 7.3.1 [Inserting the specimen discs into the specimen head](#)).
4. Make sure that the knife or blade is inserted in the knife or blade holder, see (→ P. 45 – 7.4.4 [Blade holder CE](#)) or (→ P. 52 – 7.4.6 [Knife holder CN](#)).
5. Orient the specimen (→ P. 42 – 7.3.2 [Specimen orientation](#)).
6. If necessary, adjust the clearance angle (→ P. 44 – 7.4.2 [Clearance angle adjustment](#)).
7. Check whether retraction is as wanted on or off (→ P. 38 – 6.3 [Retraction](#)).

Sectioning

1. Select trimming thickness.
2. Adjust anti-roll device (→ P. 49 – [Adjusting the anti-roll guide system](#)).
3. Trim using the handwheel (→ P. 58 – [Trimming the specimen](#)).
4. Select section thickness (→ P. 37 – 6.2.7 [Setting the section thickness](#)).
5. Carry out sectioning using the hand wheel, discard the first 2-3 sections.
6. Pick up the sections either by transferring it onto a cold slide using a cold brush or a warm slide.

Ending the sectioning process

1. Remove knife/blade out of the knife/blade holder.



Warning

The safety gloves included in the (→ P. 24 – 4.3 [Standard delivery - packing list](#)) must be worn when inserting/removing the knife!

2. Remove the specimen from the cryostat e.g. fix it for later paraffin embedding.
3. Remove section waste using a cold brush.
4. Start UVC cycle (→ P. 32 – [UVC lamp \(CM1860 UV only\)](#)).

7.2 Specimen freezing

- Select the sectioning temperature (cryochamber temperature) according to the tissue type to be sectioned (→ P. 59 – 7.5 [Temperature selection chart \(in minus °C\)](#)).

7.2.1 Quick-freeze shelf

The cryochamber is equipped with a quick freeze shelf (→ Fig. 24-5) on which up to 10 specimen stages with specimens can be stored.

The temperature of the quick freeze shelf is always lower than the cryochamber temperature.

1. Cut the specimen roughly to size.
2. If necessary, enable the Peltier element (→ Fig. 24-4) - it takes approx. 60 seconds until the maximum cooling capacity is available.
3. Apply a sufficient amount of cryocompound to a specimen disc that is at room temperature or pre-cooled.
4. Place the specimen on the disc and orient it.
5. Place the specimen disc in one of the holes of the quick freeze shelf and freeze the specimen at low temperature.
6. Once the specimen is frozen, insert the specimen disc (→ Fig. 25-3) with the specimen into the specimen head (→ Fig. 25-2) and start sectioning.



Fig. 24



Note

If the optional available stationary heat extractor is built in, see (→ P. 102 – 10.4 Stationary heat extractor (optional) - application).

7.3 Specimen discs

7.3.1 Inserting the specimen discs into the specimen head

1. Lock the handle of the handwheel in the upper position.

2. If the knife/blade holder and a knife/blade are in place, cover the knife edge with the safety guard.
3. Open the clamping screw (→ Fig. 25-1) at the specimen head.
4. Insert the shaft of the specimen disc (→ Fig. 25-3) with the frozen specimen in the location hole (→ Fig. 25-2) of the specimen head.

**Note**

Make sure that the shaft of the specimen disc is fully inserted. The entire surface of the rear side of the specimen disc must be free of residue.

5. Tighten clamping screw (→ Fig. 25-4).

**Note**

The specimen discs are to be handled by their side O-ring to protect against freezer burn!

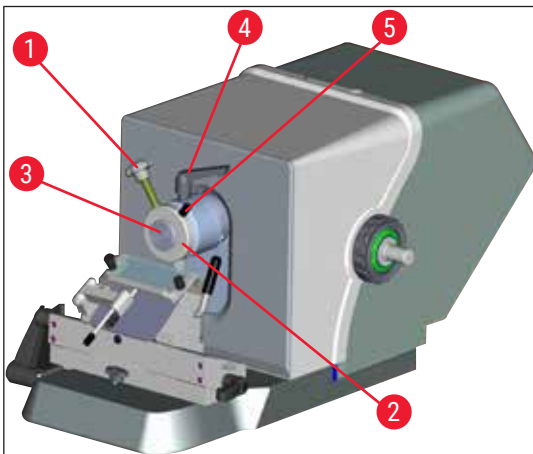

Fig. 25

7.3.2 Specimen orientation

1. Loosen the clamping lever (→ Fig. 25-4).
2. Orient the specimen on the ball shell using the lever (→ Fig. 25-5).
3. Re-tighten the clamping lever (→ Fig. 25-4).

7.4 Sectioning

7.4.1 Inserting the blade/knife holder base

1. To insert the blade/knife holder base (→ Fig. 26-1), move the lever (→ Fig. 26-2) counterclockwise to the back. Slide the base onto the t-piece (→ Fig. 26-3) of the base plate.

**Note**

When inserting the blade/knife holder base, overcome the resistance of a spring (located in the foot of the knife holder) by applying a little pressure toward the left.

2. To clamp the blade/knife holder base, turn the lever (→ Fig. 26-2) clockwise (towards the front).
3. If the blade/knife holder base is to be moved in the cryochamber, grab the base by both of the plastic points (→ Fig. 26-4) to prevent freezer burn injuries.

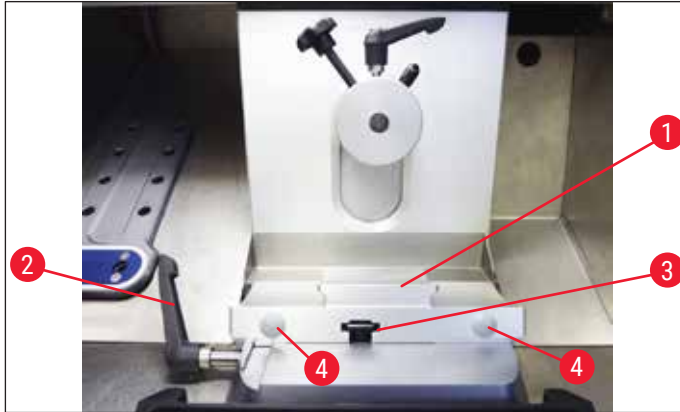

Fig. 26

Adjust the clamping force of the t-piece

To ensure a proper sectioning result, the knife holder base (→ Fig. 26-1) must be securely clamped onto the base plate (→ Fig. 27-1).

The clamping is carried out using an eccentric lever (→ Fig. 27-2). The clamping force is adjusted with the setscrew (→ Fig. 27-4) on the upperside of the t-piece. The setting of the clamping is carried out so that the clamping lever can be rotated to the stop with constantly increasing resistance.

To set the clamping distance from the eccentric bolt to approx. 200 °, do the following steps.

1. Remove the knife holder base from the base plate.
 2. Adjust by screwing clockwise or counterclockwise the countersunk screw (→ Fig. 27-3) in the clamping piece in the base using the Hexagon key No. 4, so that the eccentric lever (→ Fig. 27-2) can be clamped at 0 ° position and 200 ° position.
- ✓ Repeat this procedure until the knife holder base is securely clamped and not moving.

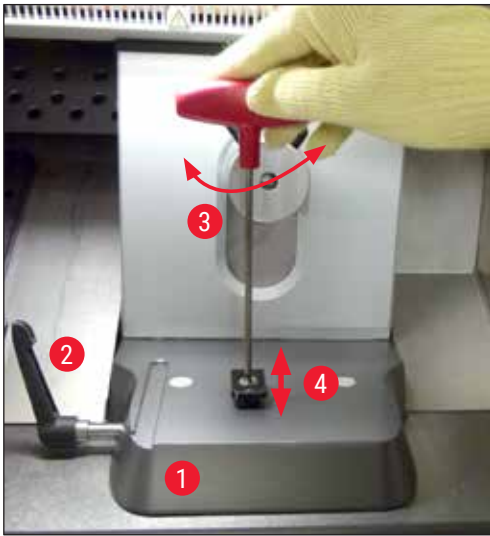

Fig. 27

7.4.2 Clearance angle adjustment



Note

- The harder the specimen is, the larger the clearance angle must be chosen.
- However: The larger the clearance angle is, the larger the section buckling becomes.
- If the clearance angle is too small, sections that are too thick or too thin can result. Also consider that the position of the knife edge relative to the specimen can change when the clearance angle is adjusted. For this reason, always place the specimen above the knife when adjusting the clearance angle. Otherwise, the specimen could hit the knife while being raised. If necessary, move the specimen backwards to avoid collisions during further trimming.
- A clearance angle that is too steep or too shallow may lead to suboptimal sectioning results and could possibly damage the specimen. We generally recommend using higher clearance angles for harder specimens and relatively lower clearance angles for softer ones.

Adjust the clearance angle if necessary:

1. The clearance angle scale is located on the left side of the blade holder.
2. Release the blade holder by turning the No. 4 Hexagon screw (→ Fig. 28-1) counterclockwise. Select a clearance angle of 0°. To do so, align the number 0 with the index mark (→ Fig. 28-2) and tighten the Hexagon screw (→ Fig. 28-1). If the sectioning results are not satisfactory, increase the clearance angle in 1° increments until you achieve optimum results.



Fig. 28

**Note**

Settings of 2° - 5° (blade holder CE, CE-TC and premium blade holder) and 4° - 6° for the knife holder CN are well-suited for most applications.

7.4.3 Premium blade holder



Fig. 29

**Note**

Please observe the Instructions for Use included in the packaging for handling the premium blade holder.

7.4.4 Blade holder CE

**Note**

If additional blade holder Instructions for Use have been provided, read and follow the instructions and safety information carefully!

Inserting the blade holder CE

- » Push the upper part of the blade holder onto the base. Clamp the blade holder into place on the left side using a Hexagon key (No. 4) (→ Fig. 30-23).

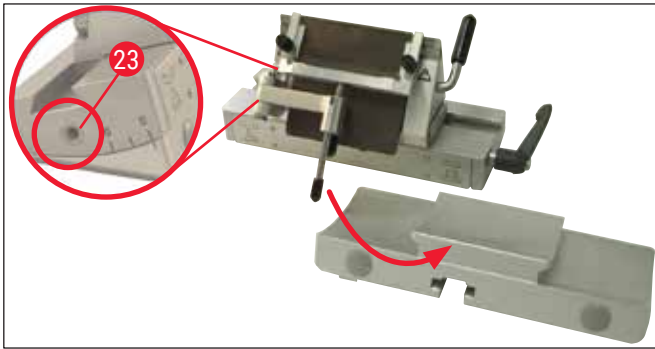

Fig. 30

Inserting the blades into blade holder CE



Warning

Caution! Microtome blades are extremely sharp!



Note

The blade holder CE can be used either for the low-profile and high-profile blades.

Inserting a high-profile blade



Warning

The safety gloves included in the (→ P. 24 – 4.3 Standard delivery - packing list) must be worn when inserting the blade!

1. Fold the anti-roll guide system (→ Fig. 31-4) towards the left – while doing so, hold the lever (→ Fig. 31-11) (**NOT** the adjusting screw of the anti-roll guide), so that the height of the anti-roll guide remains unchanged.
2. Open the clamping lever (→ Fig. 31-10) by turning it counterclockwise (→ "Fig. 31").
3. Carefully insert the blade (→ Fig. 31-9) from above or from the side between the pressure plate and the blade rest. Make sure that the blade is inserted so that it is centered and lies evenly along the ledge (see red arrow in (→ "Fig. 31")).

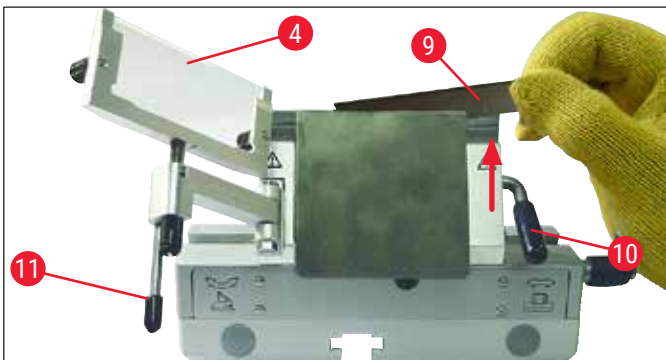

Fig. 31

4. Rotate clamping lever (→ Fig. 32-10) clockwise to clamp (→ "Fig. 32").
5. Fold the anti-roll guide system (→ Fig. 32-4) back to the right (towards the blade) using the lever (→ Fig. 32-11).

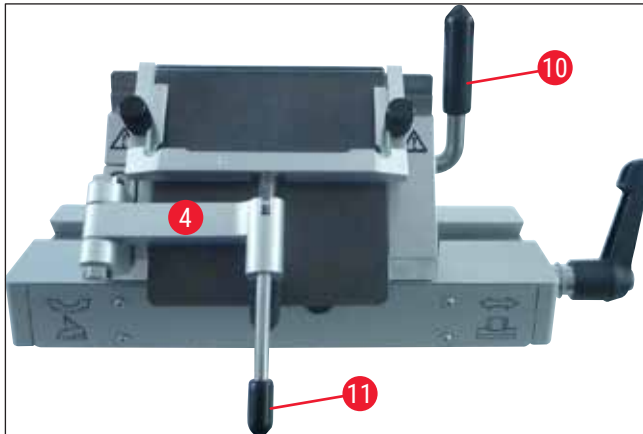

Fig. 32

**Note**

The anti-roll guide system functions as a safety guard here!

Inserting low-profile blades into the high-profile blade holder CE

- When using low-profile blades, the red guide (blade rest) (→ "Fig. 33") must first be placed in the blade holder, followed by the blade.



Fig. 33

Two magnets (→ "Fig. 34") are attached to the rear side of the guide. These point away from the operator after the guide has been inserted (towards the rear pressure plate).

Then insert the blade as described (→ P. 46 – Inserting a high-profile blade).



Fig. 34

Removing the blades

1. Fold the anti-roll guide system (→ Fig. 35-4) to the left – while doing so, hold the lever (→ Fig. 35-11) (not the adjusting screw of the anti-roll guide), so that the height of the anti-roll guide remains unchanged.
2. Open the clamping lever (→ Fig. 35-10) by turning it counterclockwise (→ "Fig. 35").

- Carefully lift out the blade (→ Fig. 35-9). Continue with instruction step 5.

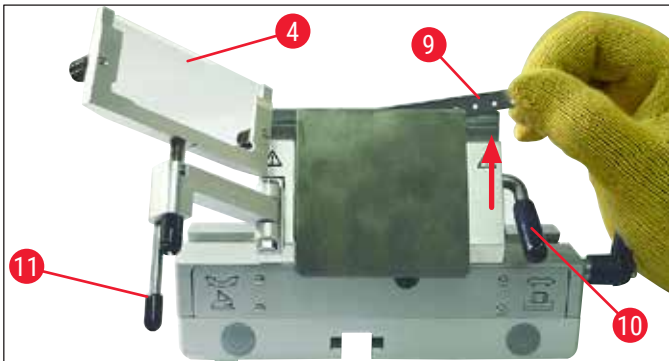

Fig. 35

- Another option for removing the blade is to use the brush with magnet (→ Fig. 36-12). To do so, fold the clamping lever (→ Fig. 36-10) downward counterclockwise (→ "Fig. 36"). Fold the anti-roll guide system (→ Fig. 36-4) to the left. Guide the brush with magnet (→ Fig. 36-1) to the blade and lift it upwards and out.

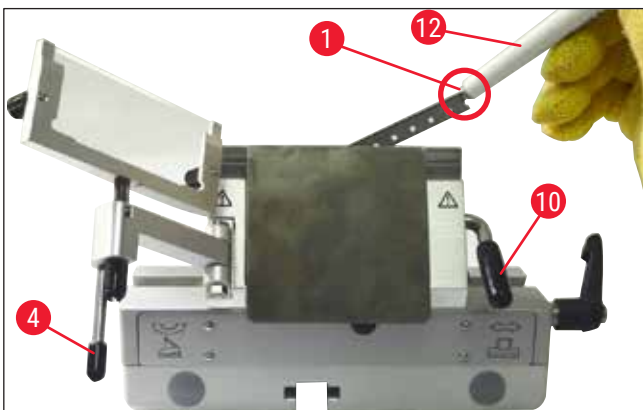

Fig. 36

- Once the blade has been removed from the blade holder, it is disposed of in the dispenser container (storage compartment in bottom (→ Fig. 37-1)).



Fig. 37

**Warning**

The safety gloves included in the (→ P. 24 – 4.3 Standard delivery - packing list) must be worn when disposing of the blade!

Lateral movement

If the sectioning results are not satisfactory, the blade holder (on a base here (→ "Fig. 38")) can be shifted sideways in order to use another part of the blade, and to benefit from the entire length of the blade.

To do so, follow these steps:

1. Turn the clamping lever (→ Fig. 38-14) to the rear (counterclockwise) to release, and then shift the blade holder sideways to the desired position.
2. To tighten, turn the clamping lever (→ Fig. 38-14) to the front (clockwise).

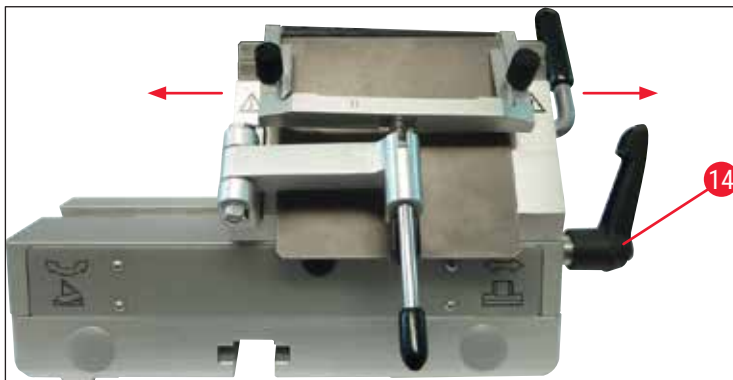

Fig. 38

Adjusting the anti-roll guide system

You can adjust the height of the anti-roll guide system using the knurled nut (→ Fig. 39-8):

- If you turn the nut counterclockwise, the anti-roll guide system moves toward the blade.
- If you turn the nut clockwise, the anti-roll guide system moves away from the blade.

If the anti-roll guide system is in the wrong position relative to the blade, the following problems will result:

- » The section rolls over the glass insert of the anti-roll guide system (→ Fig. 40-1).
- ❗ Error: Glass insert not high enough.
- ✓ Remedy: Turn the knurled nut counterclockwise until the section is pushed between the blade and anti-roll guide as shown in (→ Fig. 40-3).

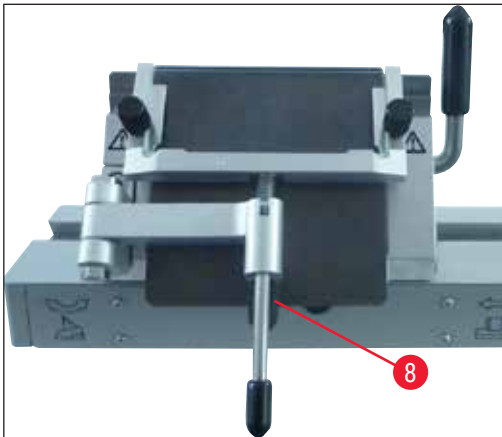

Fig. 39

- » Sections are compressed and block hits the glass insert (→ Fig. 40-2) after sectioning.
- ① Error: Anti-roll guide system is set too high.
- ✓ Remedy: Turn the knurled nut clockwise until the section is pushed between the blade and anti-roll guide as shown in (→ Fig. 40-3).

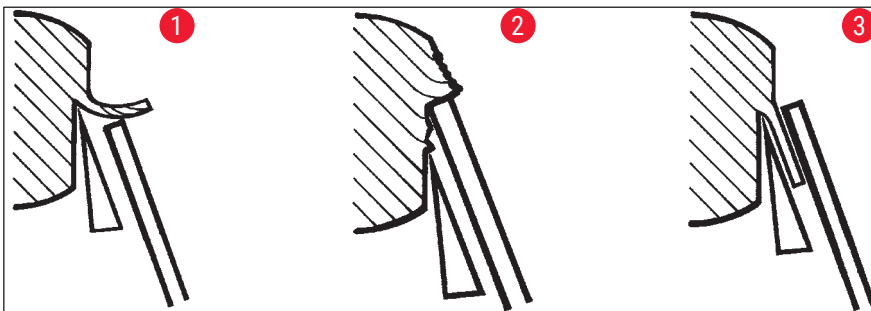

Fig. 40

**Note**

GENERALLY we recommend pre-adjusting the anti-roll guide system for high section thicknesses (e.g. 10 μm). – Start from there and work your way down to the desired section thickness in small increments, readjusting the anti-roll guide system at each increment using the knurled nut.

Assembling the anti-roll guide system/replacing the anti-roll plate

1. Insert the glass into the interchangeable frame and tighten it evenly using the knurled screws (→ Fig. 41-7).
2. Insert the shaft (→ Fig. 41-8) of the metal frame for exchangeable glass inserts from above into the hole of the swinging arm in such a way that the pin (→ Fig. 41-6) rests in the notch.
3. Push the white plastic plate (→ Fig. 41-9) from below onto the shaft (→ Fig. 41-8).
4. Screw the knurled nut (→ Fig. 41-10) from below onto the shaft (→ Fig. 41-8).

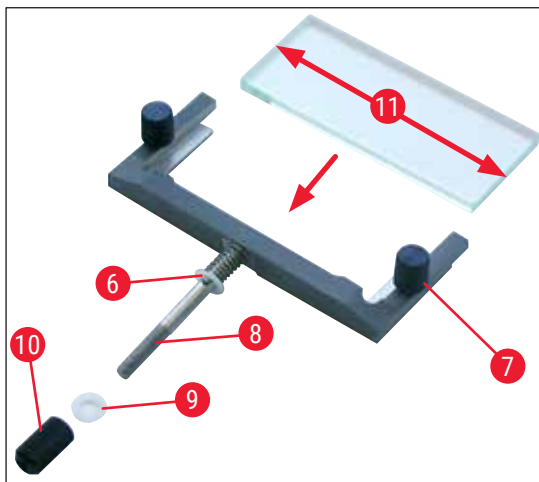

Fig. 41

Anti-roll plate (with glass stage plate)

Width: 70 mm (→ Fig. 41-11)

Available with various spacers:

- 70 mm - 50 μm , for section thickness: < 4 μm
- 70 mm - 100 μm , for section thickness: 5 μm - 50 μm
- 70 mm - 150 μm , for section thickness: > 50 μm

**Note**

All 4 longitudinal edges of the anti-roll glass plate can be used.

7.4.5 Blade holder CE-TC

The blade holder CE-TC (→ "Fig. 42") is designed only for disposable carbide metal blades (tungsten carbide - TC65).

Handling of this holder is identical to that of the blade holder CE (→ P. 45 – 7.4.4 Blade holder CE).

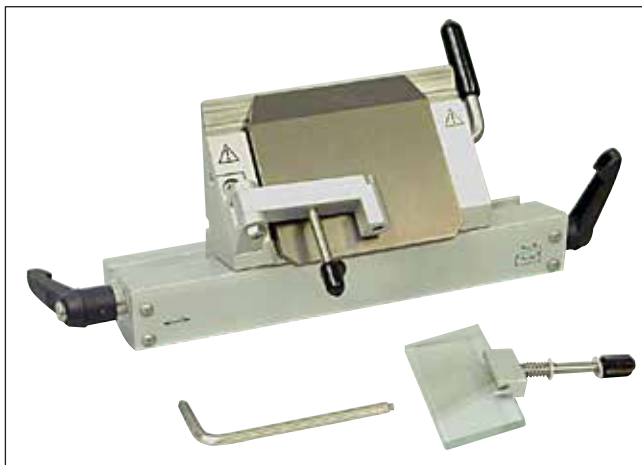

Fig. 42

7.4.6 Knife holder CN

Inserting the base

1. To insert the blade/knife holder base (→ Fig. 43-1), move the lever (→ Fig. 43-2) counterclockwise to the back. Slide the base onto the t-piece (→ Fig. 43-3) of the base plate.



Note

When inserting the blade/knife holder base, overcome the resistance of a spring (located in the foot of the knife holder) by applying a little pressure towards the left.

2. To clamp the blade/knife holder base, turn the lever (→ Fig. 43-2) clockwise (towards the front).

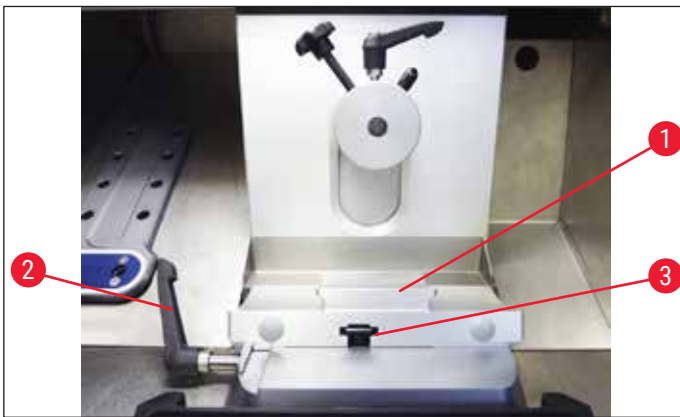

Fig. 43

Inserting knife holder CN

3. Push the knife holder (→ Fig. 44-3) onto the (→ Fig. 44-1) base. Clamp the knife holder into place on the left side using an Hexagon key (No. 4) (→ Fig. 44-23).

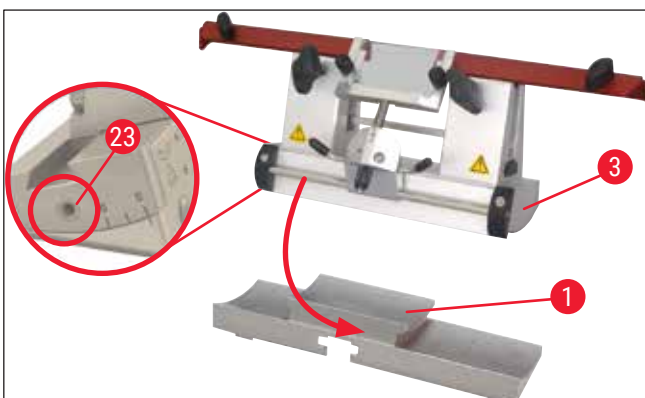

Fig. 44

**Note**

Clearance angle settings between 4° - 6° for the knife holder CN and 2° - 5° for the blade holder CE, CE-TC and premium blade holder are suitable for most applications.

Inserting/removing the knife**Note**

The height of resharpened knives must be adjusted using the knurled screws (→ Fig. 45-4) (approx. 1 mm under the edge of the clamping jaw).

Make sure that the knife is parallel from one end to the other.

**Warning**

The safety gloves included in the (→ P. 24 - 4.3 Standard delivery - packing list) must be worn when inserting/removing the knife!

- Insert the knife backrest (→ Fig. 45-3) on the side above the knurled screw (→ Fig. 45-4) so that the notch (→ Fig. 45-24) faces the user – turn the knurled screws for height adjustment until the lower position is reached.
- The knife can now be inserted from the side and its height adjusted using the knurled screws (→ Fig. 45-4). The upper edge of the rear clamping jaw serves as an index point for the correct knife height. The height of the knife blade should match that of the rear clamping jaws. This makes it possible to accurately adjust even frequently resharpened knives up to a height of 25 mm.
- Once the correct height is obtained, tighten the wingscrews (→ Fig. 45-7) in alternating order until both are tight.

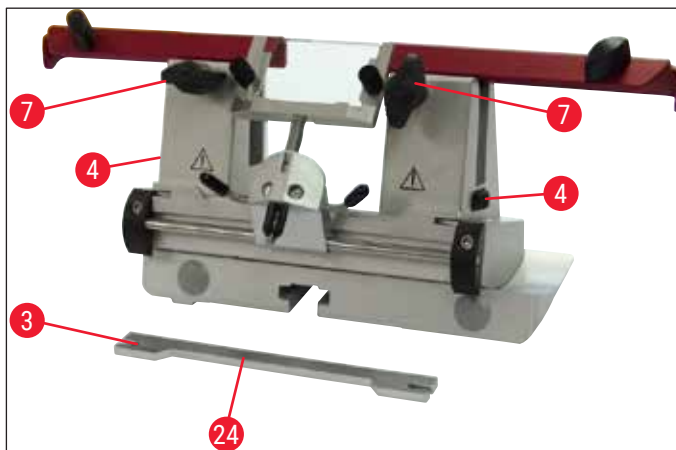

Fig. 45

- To remove the knife, follow these instructions in reverse order.
- Open the wingscrews by turning them counterclockwise and then pull the knife out to the side.



Warning

- After the knife has been removed from the knife holder, it is stored securely in the knife case (→ "Fig. 46"). **NEVER** place the knife without the knife case onto the work surface next to the instrument!
- To prevent the knife from rust, close knife case when the knife is completely dry.



Fig. 46

Safety guard/lateral movement for knife holder CN

The safety guard (→ Fig. 47-18) is secured and integrated into the clamping jaws. The safety guard has handles (→ Fig. 47-19) that allow it to be moved. The safety guard is suitable for knives up to 16 cm in length. Always cover exposed parts of the knife blade after sectioning.

The anti-roll guide system can be moved sideways (only for the 84 mm variant). To better find the mid position, a groove (→ Fig. 47-17) is provided in the shaft (→ Fig. 47-16) in which the anti-roll guide sits.

- The CN knife holder can be used to hold tungsten-carbide or steel knives.

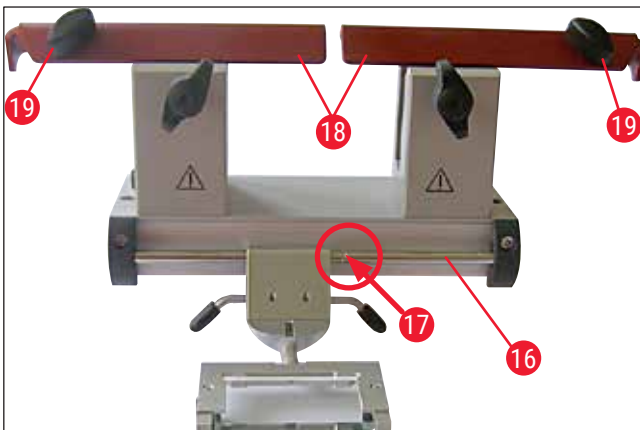

Fig. 47



Warning

The safety guard must never be uninstalled!

Clearance angle adjustment

The clearance angle adjustment for the knife holder CN is carried out exactly as described for the blade holder CE (→ P. 44 – 7.4.2 Clearance angle adjustment).

Adjusting the anti-roll guide

The anti-roll guide adjustment for the knife holder CN is carried out exactly as described for the blade holder CE (→ P. 49 – Adjusting the anti-roll guide system).

To move it laterally, see (→ "Fig. 47").

Knife holder CN with anti-roll guide – Moving the clamping jaws



Note

If large specimen discs are to be used with the knife holder (e.g. 50 x 80 mm), it is possible to shift the clamping jaws laterally.

The clamping jaws are factory-installed in the knife holder with a clearance of 64 mm. If necessary, both clamping jaws can be set with a clearance of 84 mm.

Perform the following steps:

1. Use a No. 4 Hexagon key to loosen the screw over the clearance angle adjustment (→ Fig. 48-23) and remove the segment arc (→ Fig. 48-2) from the blade/knife holder base.

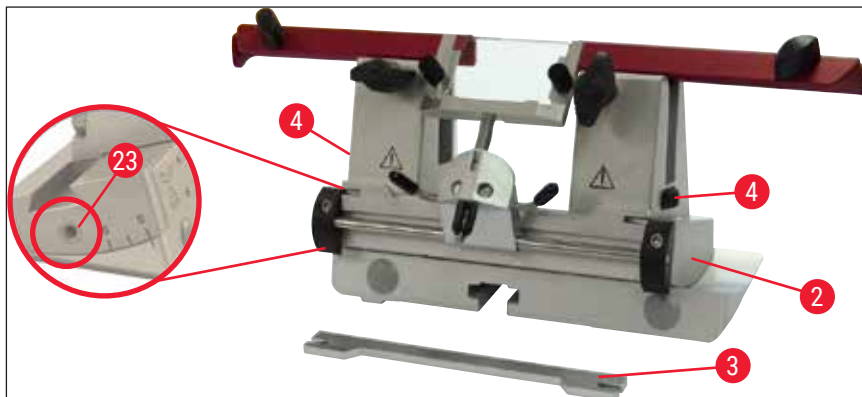

Fig. 48

2. Use a No. 4 Hexagon key to loosen the screws (→ Fig. 49-4) on the underside of the segment arc.

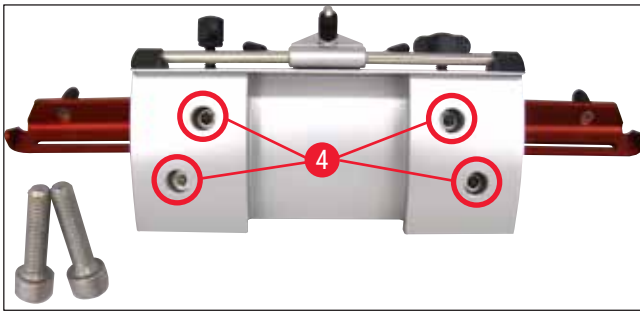

Fig. 49

**Warning**

Never work with only one clamping jaw, as this does not ensure the stability required for the sectioning process. Also, a long knife will not be sufficiently protected by the safety guard in this instance.

3. Lift off the clamping jaw (→ Fig. 50-5) on the right side (caution: do not lose the washers!) and feed it into the adjacent hole (→ Fig. 50-6). Tighten the screws from the underside of the segment arc. Repeat on the left side.

✓ Now use the longer knife backrest provided.

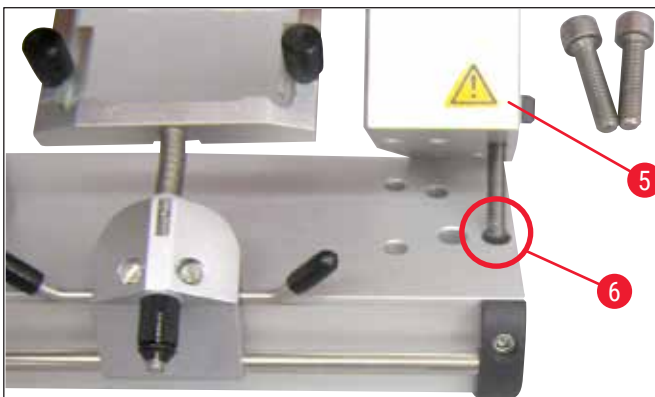

Fig. 50

7.4.7 Cleaning the blade and knife holders**Note**

- For daily cleaning, just remove the section waste from the blade/knife holder using a dry brush. Please use a cold brush, as otherwise the section waste will thaw and stick to the blade or knife holder.
- Mechanical damage to the pressure plate will strongly affect the sectioning quality. For this reason it is important to ensure that the clamping area is not damaged during cleaning or other work.
- For disinfection purposes, standard commercial detergents and disinfectants can be used at room temperature outside of the cryostat chamber.
- Wear gloves during cleaning to prevent freezer burn.

Blade holder CE

1. To release the segment arc (→ Fig. 51-2) from the base, use a No. 4 Hexagon key to loosen the screw over the clearance angle adjustment (→ Fig. 51-23) and remove the segment arc (→ Fig. 51-2) from the blade/knife holder base.
2. Fold the anti-roll guide system (→ Fig. 51-4) to the left while holding the lever (→ Fig. 51-11).
3. Loosen the pressure plate clamping lever (→ Fig. 51-10) by turning it counterclockwise and pull it out.
4. Afterwards, the pressure plate (→ Fig. 51-1) can be removed for cleaning (with alcohol).
5. Loosen the blade holder clamping lever (→ Fig. 51-12) by turning it counterclockwise and pull it out. The blade holder can now be moved sideways and can be taken out of the segment arc.

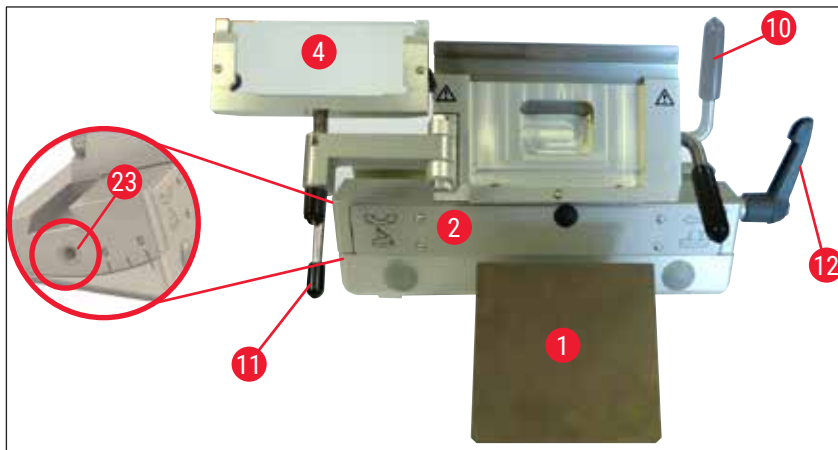

Fig. 51

Knife holder CN

- Occasionally oil the moving parts such as the axes (→ Fig. 52-1) and (→ Fig. 52-2) as well as the slot (→ Fig. 52-3) with a drop of cryo oil.

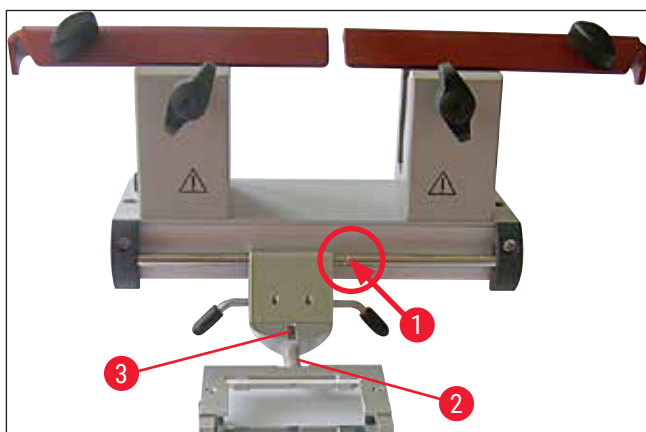

Fig. 52

**Note**

If several blade/knife holders are cleaned at the same time, the parts must **NOT** be mixed up! Failure to adhere to this may result in sectioning problems!

Disinfection

- At room temperature, wipe contaminated surfaces with a paper towel moistened with alcohol-based disinfectants.

**Warning**

Also observe the warning messages in ([→ P. 69 – 9. Cleaning, Disinfection, Maintenance](#)).

Trimming the specimen**Warning**

Take care when handling microtome knives and disposable blades. The cutting edge is extremely sharp and can cause serious injuries! For that reason, always wear the cut-resistant safety gloves included in the standard scope of delivery!

Always clamp the specimen **BEFORE** clamping the knife or the blade.

Lock the handwheel and cover the knife edge with the safety guard prior to any manipulation of knife/ blade or specimen, prior to changing the specimen block and during all work breaks!

1. Insert the pre-cooled knife/disposable blade into the knife/blade holder.
2. Adjust the knife holder to an appropriate clearance angle. Settings from 4° - 6° (knife holder CN) and 2° - 5° (blade holder CE, CE-TC and premium blade holder) are suitable for most applications.
3. Align the knife/knife holder or blade/blade holder with the specimen.
4. Move the safety guard (knife holder CN) to the side or fold the glass anti-roll guide (blade holder CE, CE-TC and premium blade holder) over to the side.
5. Unlock the handwheel.
6. To trim the specimen, move the specimen towards the knife using the coarse feed buttons. Trim the specimen down to the required sectioning plane by turning the handwheel ([→ P. 37 – 6.2.7 Setting the section thickness](#)).
7. For section removal, fold the anti-roll guide on the knife and align it with the blade edge.
8. Readjust the anti-roll guide if necessary ([→ P. 49 – Adjusting the anti-roll guide system](#)) for the blade holders and ([→ P. 55 – Clearance angle adjustment](#)) the knife holders.

7.5 Temperature selection chart (in minus °C)

Tissue type	-10 °C - -15 °C	-15 °C - -25 °C	-25 °C - -30 °C
Adrenal	❄	❄	
Bone marrow		❄	
Brain		❄	
Bladder		❄	
Breast - fatty			❄
Breast - little fat		❄	
Cartilage	❄	❄	
Cervical		❄	
Fatty			❄
Heart and vascular		❄	
Intestinal		❄	
Kidney		❄	
Laryngeal		❄	
Lip		❄	
Liver		❄	
Lung		❄	
Lymphoid		❄	
Muscle		❄	
Nose		❄	
Pancreatic		❄	
Prostate		❄	
Ovarian		❄	
Rectal		❄	
Skin with fat			❄
Skin without fat		❄	
Spleen or bloody tissue		❄	
Testicular		❄	
Thyroid		❄	
Tongue		❄	
Uterus curettage	❄		

The temperature values given in this table are based on experience; however, these are only reference values. Each tissue may require individual temperature adjustments.

7.6 Defrosting

Defrosting the cryochamber actually means defrosting the evaporator to prevent excessive frost buildup. The evaporator is flushed with hot gas during defrosting. The cryochamber itself is not being defrosted.

The condensation water that is produced during defrosting is collected in a container that is accessible from the outside.



Warning

To make sure that the condensation water stemming from the defrost cycles drains into the waste container and to avoid the risk of possible contamination, ensure that the tap of the waste container (→ Fig. 55-2) is open whenever operating the cryostat.

Only shut the tap when draining the waste container!



Note

The quick freeze shelf is cooled during the automatic cryochamber defrosting. However, the Peltier element is turned off.

The maximum duration of a defrost cycle is 12 minutes. Defrosting is terminated automatically once the cryochamber has reached a temperature of -5 °C . Cooling turns back on automatically.

7.6.1 Automatic defrosting of the cryochamber

One automatic defrost of the cryochamber takes place per day.

You can program the time of the automatic defrost cycle on control panel 1 (→ P. 34 – 6.2.2 Setting the automatic defrost time (cryochamber)).

7.6.2 Manual defrosting of the cryochamber



Note

To avoid an unintended defrosting, the activation of a manual defrost cycle is confirmed by an audible signal.

Cooling turns back on automatically.

To avoid frost formation, always put the proper cover on the quick freeze shelf. Always cover the quick freeze shelf during breaks and overnight.

In addition to the programmed automatic defrost, a manual defrost for the cryochamber can also be activated (→ P. 37 – 6.2.6 Manual defrosting of the cryochamber).

7.6.3 Manual defrosting of the quick freeze shelf



Warning

The quick freeze shelf can become hot during the defrosting process. Therefore, do not touch it!

In case of heavy frost formation on the quick freeze shelf, a defrost can be activated manually (→ P. 36 – 6.2.5 Manual defrosting of the quick freeze shelf), which can be terminated when required.



Note

To avoid frost formation always put the cover on the quick freeze shelf. Always cover the quick freeze shelf during breaks and overnight.

7.7 Ending work

7.7.1 Finishing the daily routine

1. Lock the handwheel.
2. Take the knife/blade out of the knife/blade holder and put it back into the knife case/blade dispenser in the cryochamber.
3. Remove frozen section waste with a cold brush.
4. Empty the section waste tray.
5. Clean the storage shelves and brush shelf.



Note

- Only common detergents and alcohol-based disinfectants should be used for cleaning.
- All components removed from the cold environment will collect condensation. Therefore, dry them thoroughly before placing them back into the cryostat.
- Remove all tools and supplies that would prevent the UVC light from reaching the chamber walls and shelves.

6. Remove all specimen material from the cryostat.
7. Attach the cover for the freeze shelf.
8. Close the sliding window.
9. Switch off the chamber illumination and start the UVC cycle.
10. Lock control panel 1 (→ P. 32 – Fig. 14) using the **Key** button.
11. Do **NOT** switch off the instrument using the circuit breaker, as otherwise no cooling takes place.

7.7.2 Switching off the instrument for a longer period



Note

If you do not intend to use the instrument for several weeks you may turn it off. Please note, however, that it may take up to several hours to cool the cryochamber down to very low temperatures after turning the instrument on again. After switching off the instrument, it must be cleaned and disinfected thoroughly (→ P. 69 – 9. Cleaning, Disinfection, Maintenance).

1. Lock the handwheel.
2. Take the blade/knife out of the blade/knife holder. Put the knife back in the knife case; Push the blade into the receptacle for used blades provided at the bottom of the dispenser (→ "Fig. 37").
3. Remove all specimen material from the cryostat.
4. Remove the blade/knife holder out of the cryochamber.
5. Remove section waste with a cold brush.
6. Empty the section waste tray.
7. Switch the instrument off at the circuit breaker and unplug the power plug.
8. Remove the storage shelves and the brush shelf for cleaning and disinfection.
9. Remove the rubber plug. Dispose of the collected defrosting fluid in accordance with the laboratory specifications.
10. Wipe the cryostat chamber using a paper towel moistened with an alcohol-based disinfectant.
11. Let the sliding window open to allow the cryochamber to dry and the disinfectant to evaporate.



Note

Switching off the instrument via the **circuit breaker** will not affect the programmed values. Before turning the instrument on again, the cryochamber, the microtome and all accessory components must be absolutely dry.

8. Troubleshooting

8.1 Error messages in the display

Error messages are displayed on the clock panel as follows **EO: XX** (→ "Fig. 53"). The following error messages might occur during operation:



Fig. 53

Error	Cause	Remedy
20	Calibration error; possibly defective controller board.	Switch the instrument off for 10 seconds and then back on. If the error is displayed again: Call service.
21	Clock battery on the controller board empty.	Call service.
23	The cryochamber temperature is outside the display range from 35 °C to -55 °C.	Eliminate cause.
25	Temperature sensor for cryochamber temperature defective.	Call service.
27	Temperature sensor for defrost limiter defective.	Call service.
28	Both light barriers in the handwheel active.	Call service.
29	Service interval warning after 15960 hours.	Call service.
30	Service interval expired after 17610 hours.	Call service.



Note

If errors occur, they are output as error codes in the real-time display during normal operation with the format **EO:XX** (→ "Fig. 53").

- In normal operation, the error displayed can be acknowledged by pressing any key once. Error codes 21-28 are self-acknowledging if their cause has been eliminated.
- After 15960 hours, **HELP** is output in the real-time display to indicate the need for service maintenance. The display alternates between **HELP** and the real-time display. The message is acknowledged by pressing a key on the keyboard. The **HELP** display keeps appearing at a relatively long interval.
- After 17610 hours, **HELP** is output in the real-time display to indicate the need for service maintenance. The display alternates between **HELP** and the real-time display. The message is acknowledged by pressing a key on the keyboard. The **HELP** display keeps appearing at a relatively short interval.

8.2 Temperature control button

On the back of the instrument there is a temperature control button (→ Fig. 54-1). If the temperature of the cryochamber exceeds 60 °C the switch responds automatically and turns the instrument off.



Fig. 54

Possible causes and remedies:

1. Temperature of the immediate surroundings is constantly higher than 40 °C.
 - ✓ Drop the temperature of the immediate surroundings.
2. When setting up the instrument, the minimum clearance (→ P. 21 – 4.1 Installation site requirements) to walls and furniture was not kept.
 - ✓ Observe the minimum clearance.
3. The air inlet openings of the condenser are dirty.
 - ✓ Clean the air inlet openings (→ Fig. 57-5).

**Warning**

- Avoid contact with condenser fins as sharp edges may cause personal injury.
- Insertion of any object into condenser fans is to be avoided as this may result in personal injury and/or device damage.
- Wear cut resistant gloves during cleaning.
- In case of visible pollution (such as dust), clean the air inlet opening of the condenser on the bottom right-hand side of the instrument using a brush, broom or vacuum cleaner in the direction of the louvers.

After eliminating the possible sources of error, push the temperature control button (→ Fig. 54-1) to turn the instrument back on and make it ready to operate. If the instrument does not respond, contact service.

8.3 Possible sources of error, causes and remedies

Problem	Cause	Remedy
Frost on cryochamber walls and microtome.	<ul style="list-style-type: none"> • The cryostat is exposed to air currents (open windows, doors, air conditioning). • Sliding window was open too long at a very low cryochamber temperature. • Frost built up by breathing into the cryochamber. 	<ul style="list-style-type: none"> • Eliminate cause or relocate instrument. • Close the sliding window correctly. • Wear a mask if necessary.
Ice formation on the bottom of the cryochamber.	<ul style="list-style-type: none"> • Shut-off valve of condensate drain closed. • Draining of condensation water of the quick freeze shelf defrosting system obstructed. 	<ul style="list-style-type: none"> • Open the shut-off valve, switch off the instrument and let it thaw and dry. • Level the instrument.
Lubricate sections.	<ul style="list-style-type: none"> • Specimen not cold enough. • Knife and/or anti-roll plate not yet cold enough – the section melts as a result. 	<ul style="list-style-type: none"> • Select lower temperature. • Wait until knife and/or anti-roll plate have reached cryochamber temperature.
Sections splinter, cracks in the section.	<ul style="list-style-type: none"> • Specimen too cold. 	<ul style="list-style-type: none"> • Select higher temperature.
Sections not properly flattened.	<ul style="list-style-type: none"> • Static electricity/air currents. • Specimen not cold enough. • Large-scale specimen. • Anti-roll plate poorly positioned. • Anti-roll plate poorly aligned with knife edge. • Incorrect clearance angle. • Knife dull or jagged. 	<ul style="list-style-type: none"> • Eliminate cause. • Select lower temperature. • Trim the specimen parallel; increase section thickness. • Reposition anti-roll plate. • Align correctly. • Set the correct clearance angle. • Use a different part of the knife.
Sections not properly flattened despite correct temperature and correctly aligned anti-roll plate.	<ul style="list-style-type: none"> • Dirt on knife and/or anti-roll plate. • Edge of anti-roll plate damaged. • Dull knife. 	<ul style="list-style-type: none"> • Clean with dry cloth or brush. • Replace anti-roll plate. • Use a different part of the knife.
Sections curl on anti-roll plate.	<ul style="list-style-type: none"> • Anti-roll plate does not protrude far enough beyond the knife edge. 	<ul style="list-style-type: none"> • Align anti-roll plate correctly.
Scraping noise during sectioning and specimen head return stroke.	<ul style="list-style-type: none"> • Anti-roll plate protrudes too far beyond the knife edge and is scraping against the specimen. 	<ul style="list-style-type: none"> • Align anti-roll plate correctly.

Problem	Cause	Remedy
Uneven sections.	<ul style="list-style-type: none"> • Knife damaged. • Edge of anti-roll plate damaged. 	<ul style="list-style-type: none"> • Use a different part of the knife. • Replace anti-roll plate.
Chatter during sectioning.	<ul style="list-style-type: none"> • Specimen insufficiently frozen onto the specimen disc. • Specimen disc not clamped tightly. • Ball-and-socket joint of the specimen holder not clamped into place tightly. • Knife not clamped tightly enough. • Specimen has been sectioned too thickly and has detached from the disc. • Very hard, inhomogeneous specimen. • Dull knife. • Knife profile inappropriate for this specimen used. • Incorrect clearance angle. 	<ul style="list-style-type: none"> • Refreeze specimen onto the disc. • Check clamping. • Check clamping of the ball-and-socket joint. • Check knife clamping. • Refreeze specimen onto the disc. • Increase section thickness; reduce specimen surface area if necessary. • Use a different part of the knife. • Use knife with different profile. • Make clearance angle adjustment.
Condensation on anti-roll plate and knife during cleaning.	<ul style="list-style-type: none"> • Brush, forceps, cloth or other cleaning materials too warm. 	<ul style="list-style-type: none"> • Use only cooled components and cleaning materials. Store all tools on storage shelf in the cryochamber.
Anti-roll plate damaged after adjustment.	<ul style="list-style-type: none"> • Anti-roll plate too high above the knife edge. The adjustment was carried out in the direction of the knife. 	<ul style="list-style-type: none"> • Replace anti-roll plate; then lift it during adjustment. • Handle anti-roll plate more carefully.

Problem	Cause	Remedy
Thick/thin sections.	<ul style="list-style-type: none"> • Temperature incorrect for the tissue to be sectioned. • Knife profile being used is inappropriate for this specimen. • Ice formation on back of knife. • Handwheel speed not uniform or turned at incorrect speed. • Knife not clamped tightly enough. • Specimen holder not clamped tightly. • Cryocompound applied to cold specimen disc; specimen can detach from the disc after freezing. • Dull knife. • Incorrect clearance angle. 	<ul style="list-style-type: none"> • Select the correct temperature and wait until the correct temperature is reached. • Use knife with different profile (c or d) or switch to disposable blades if necessary. • Remove ice. • Adapt speed. • Check clamping. • Check clamping. • Apply cryocompound on lukewarm disc; mount specimen in cryochamber and freeze it. • Use a different part of the knife. • Set the correct clearance angle.
Tissue adheres to the anti-roll plate.	<ul style="list-style-type: none"> • Dried specimen. • Anti-roll plate is too warm or incorrectly positioned. • Static charge. • Grease on the corner or edge of anti-roll plate. • Rust on the knife. 	<ul style="list-style-type: none"> • Prepare new specimen. • Cool down anti-roll plate or reposition correctly. • Remove static charge. • Remove grease using alcohol. • Remove rust.
Flattened sections curl up when anti-roll plate is folded up.	<ul style="list-style-type: none"> • Static charge or air current. • Anti-roll plate too warm. 	<ul style="list-style-type: none"> • Remove static charge. • Cool down anti-roll plate.
Sections tear or separate.	<ul style="list-style-type: none"> • Temperature too low for the tissue being sectioned. • Dull part, dirt, dust, frost or rust on the knife. • Top edge of the anti-roll plate damaged. • Hard particles in the tissue. • Dirt on back of knife. • Nick in the cutting edge of the blade or knife. 	<ul style="list-style-type: none"> • Select higher temperature and wait. • Remove cause, clean. • Replace anti-roll plate. • If the application permits, cut deeper during sectioning. • Clean. • Use a different part of the blade/knife.
Inconsistent or inaccurate specimen feed.	<ul style="list-style-type: none"> • Microtome defective. 	<ul style="list-style-type: none"> • Call technical service.

Problem	Cause	Remedy
Specimen disc cannot be removed.	<ul style="list-style-type: none"> Moisture on the underside causes the specimen disc to freeze to the freezing shelf or specimen head. 	<ul style="list-style-type: none"> Apply concentrated alcohol to the contact point or heat the specimen head.
Cryostat non-operational.	<ul style="list-style-type: none"> Power plug not properly connected. Circuit breaker is switched off. 	<ul style="list-style-type: none"> Check if power plug is properly connected. Move the switch back to the upper click stop.
Insufficient cooling capacity or none at all.	<ul style="list-style-type: none"> Compressor defective. Refrigeration system leak. Inappropriate site conditions. 	<ul style="list-style-type: none"> Call technical service. Call technical service. Check installation site requirements (→ P. 21 – 4.1 Installation site requirements). Clean air inlet opening.
Scraping noise at the slot cover of the microtome.	<ul style="list-style-type: none"> Air inlet opening of the condenser dirty. Friction between the slot cover and the microtome housing. 	<ul style="list-style-type: none"> Apply cryo oil to the slot cover and distribute it by moving the handwheel or using a clean cloth.
Both UVC lamp indicator lights flashing alternately.	<ul style="list-style-type: none"> UVC lamp is end of life. 	<ul style="list-style-type: none"> Replace UVC tube following the manufacturer's instructions.
Blade/Knife holder base can not be clamped tightly.	<ul style="list-style-type: none"> Insufficient clamping force of the t-piece. 	<ul style="list-style-type: none"> Adjust the clamping force of the t-piece (→ P. 43 – Adjust the clamping force of the t-piece).

8.3.1 Changing the battery

The battery is exchanged during routine maintenance.

If the customer has decided against a service contract, the battery must be replaced after 7 years at the latest. All settings (time, defrost time, section thickness etc.) are lost when the instrument is switched off.

There is no danger for the instrument. However, the customer must re-enter the setting values when switching the instrument on for the first time after changing the battery.

9. Cleaning, Disinfection, Maintenance

9.1 Cleaning



Warning

- Wear protective clothing during any cleaning or disinfection work (gloves, face mask, lab coat, etc.).
- Do not use any solvents (xylene, acetone, etc.) for cleaning or disinfection.
- When using detergents and disinfectants, observe the specifications of the respective manufacturer.
- Risk of explosion when using alcohol: Provide proper ventilation and ensure the instrument is switched off.



Note

- Remove frozen section waste from the cryostat with a cold brush daily.

9.2 Disinfection at room temperature



Warning

- Wear protective clothing during disinfection work (gloves, face mask, lab coat, etc.).
- When using detergents and disinfectants, observe the specifications of the respective manufacturer.
- Risk of explosion when using alcohol: Provide proper ventilation and ensure the instrument is switched off.
- Before switching on the instrument again, proper ventilation of the chamber shall be ensured.
- Ensure that you are following local regulations for disinfection.



Note

- If the cryostat is completely defrosted, the rubber plug on the floor of the cryochamber must be removed. Afterward, reinsert rubber plug and check that it is securely in place.
- The defrosting fluid is collected in a waste container (→ Fig. 55-1).

1. Switch off the instrument.
2. Carefully remove the knife/disposable blade as well as specimens and accessories from the chamber.
3. Remove the section waste from the cryochamber and dispose of it.
4. Remove the closed sliding window from the front by gently lifting it (→ P. 73 – 9.3.3 Replacement of the UVC lamp).
5. Clean the chamber walls using a paper towel moistened with an alcohol-based disinfectant.
6. Pull the rubber plug out of the bottom of the chamber and drain the disinfectant into the waste container.
7. Use the rubber plug to re-seal the drain in the cryochamber.
8. Drain the cleaning liquid through the hose after the prescribed reagent time is over (→ Fig. 55-2) and collect it in the waste container (→ Fig. 55-1).
9. To remove the waste container (→ Fig. 55-1) shut off the tap (→ Fig. 55-2) and unscrew the cover (→ Fig. 55-3).
10. Dispose of liquid according to the waste disposal regulations.
11. Allow the cryochamber to dry thoroughly.

12. Insert the disinfected accessories and tools back into the cryochamber only once they are fully dry.
13. Switch on the instrument.
14. Once a suitable cryochamber temperature has been reached, return the specimens to the cryochamber.

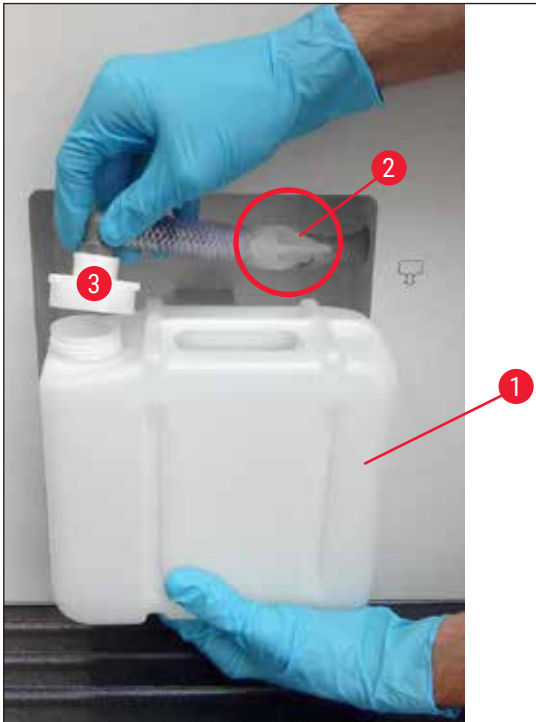

Fig. 55



Note

The waste container (→ Fig. 55-1) collects the condensate that accumulates during defrosting. Therefore, check the level regularly and empty the container according to applicable laboratory regulations.

9.3 Maintenance

9.3.1 General maintenance instructions

To ensure a smooth operation of the instrument over a long period of time we recommend the following:

- At least once a year, have the instrument inspected by a qualified service engineer authorized by Leica.
- Enter into a service contract at the end of the warranty period. For further information, please contact your local Leica service center.
- Clean the instrument **DAILY**.

Weekly:**Note**

Before the following parts can be lubricated, all section waste and deposits must be carefully removed.

- Lubricate the plastic coupling (→ Fig. 58-6) with a drop of cryo oil.
- Lubricate the specimen cylinder (→ Fig. 56-1):
 - » Push the appropriate coarse feed button to move the specimen cylinder out to the front stop position, apply a drop of cryo oil and move the specimen cylinder back to the home position by pressing the appropriate coarse feed button.

Occasionally, or when required:

- Apply a drop of cryo oil to the clamping piece (t-piece) (→ Fig. 56-2) on the microtome base plate and the clamping lever (→ Fig. 56-3).
- Lubricate the slot cover (→ Fig. 56-4).
 1. To do so, first move the specimen head all the way upwards by turning the handwheel, apply a few drops of cryo oil to the slot cover.
 2. Then, move the specimen head all the way down and apply a few drops of cryo oil to the slot cover.
 3. Distribute the oil by turning the handwheel or using a clean cloth.
- In case of visible pollution (such as dust), clean the air inlet opening (→ Fig. 57-5) of the condenser on the bottom right-hand side of the instrument using a brush, broom or vacuum cleaner in the direction of the louvers.

**Warning**

- Avoid contact with condenser fins as sharp edges may cause personal injury.
- Insertion of any object into condenser fans is to be avoided as this may result in personal injury and/or device damage.
- Wear cut resistant gloves during cleaning.
- In case of visible pollution (such as dust), clean the air inlet opening of the condenser on the bottom right-hand side of the instrument using a brush, broom or vacuum cleaner in the direction of the louvers.

**Note**

- Do not carry out any repairs on your own as this will invalidate the warranty. Repairs may only be carried out by qualified service engineers authorized by Leica.

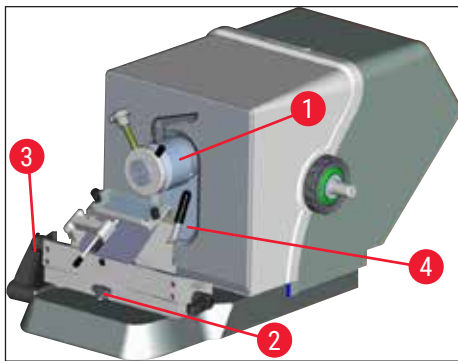

Fig. 56



Fig. 57

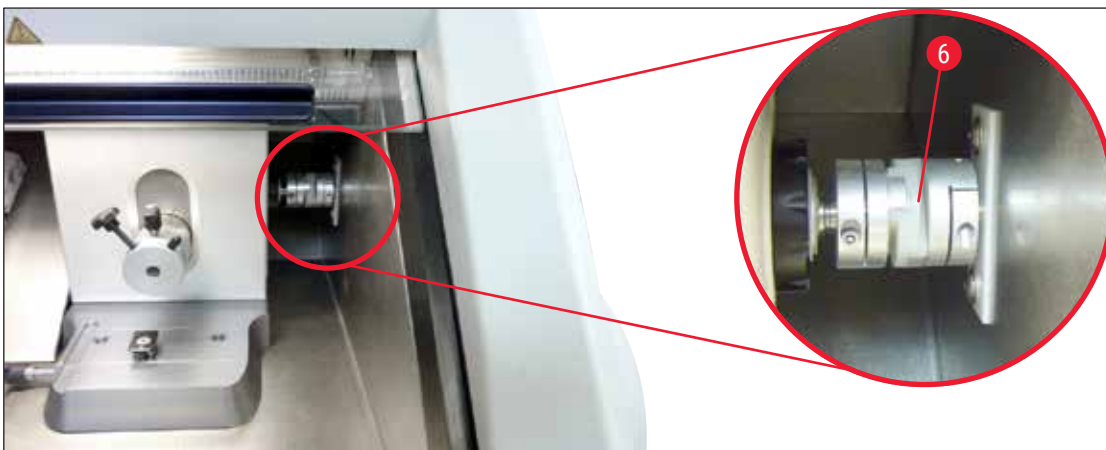

Fig. 58

9.3.2 Replacing the fuses



Warning

- Turn the instrument off and disconnect the power plug before replacing the fuses!
- Use only the fuse types specified in (→ P. 18 – 3. Technical Data).
- Failure to comply with this can cause severe damage to the instrument and its surroundings as well as endangering life and limb!

On the back of the instrument there is a fuse board with 4 fuses (→ "Fig. 59"):

1. Unscrew the sleeve of the defective fuse using the screwdriver.
2. Remove the sleeve and fuse.

3. Insert the defined fuse into the sleeve, then use the screwdriver to screw the sleeve back in as far as it will go.

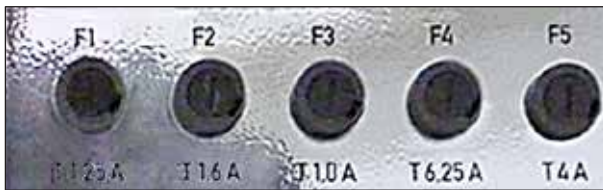

Fig. 59

Fuse	Function/protection	Type
F1	Empty	
F2	Coarse feed	T 1.6 A
F3	Processor board power supply	T 1.0 A
F4	Heaters	T 6.25 A
F5	Peltier element	T 4 A

9.3.3 Replacement of the UVC lamp



Warning

Switch the instrument off and disconnect the power plug before replacing the UVC lamp! Wear suitable safety gloves and safety glasses.
If the lamp is broken, it must be replaced by the service technician, as the replacement involves a high risk of injury.



A UVC lamp has an estimated lifetime of approx. 9000 hours.

Each on/off switching cycle reduces the lamp life by approx. one hour plus burning time (30 minutes or 180 minutes respectively).



Note

When both UVC lamp indicator lights (short and long-term cycle) in control panel 1 are flashing alternately, the UVC lamp must be replaced.

1. Switch off the instrument at the circuit breaker.
2. Disconnect the power plug.
3. Slightly lift the heated sliding window (→ Fig. 60-1) holding it by the grip (→ Fig. 60-2) and pull it out to the front.

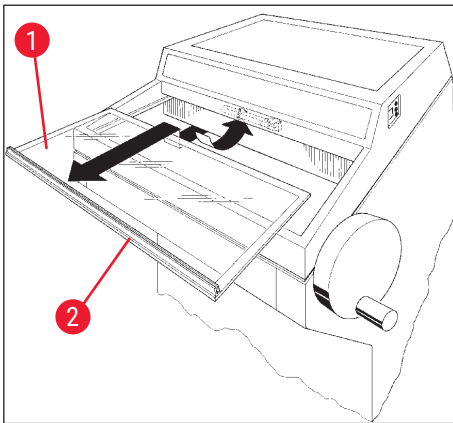

Fig. 60

**Note**

For the CM1860UV, two different variants of the connection piece inside the instrument and the UVC-Lamp are available. The user needs to check which variant is built-in in the instrument prior to the exchange of the UVC-Lamp with a new one.

The procedure to exchange the UVC-Lamp is similar with both variants.

Identifying the built-in variant and matching UVC lamp

- ① Variant 1: Connection piece with 2-pin inlet (→ Fig. 61-1), UVC lamp 2-pin (→ Fig. 61-2).

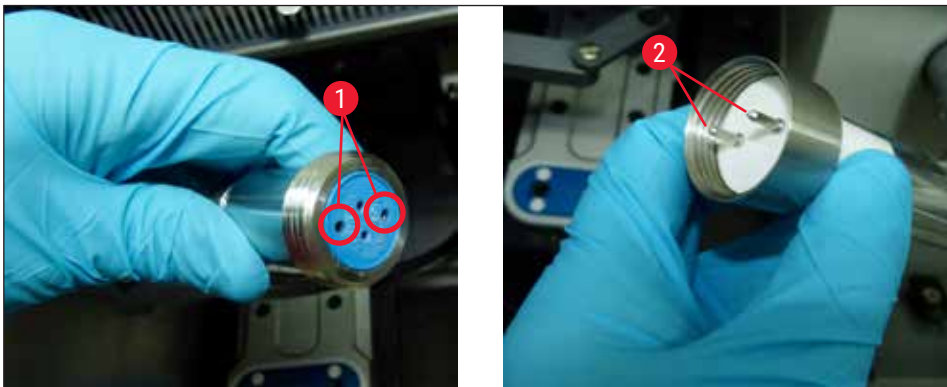

Fig. 61

- ① Variant 2: Connection piece with 4-pin inlet (→ Fig. 62-2), UVC lamp 4-pin (→ Fig. 62-1).

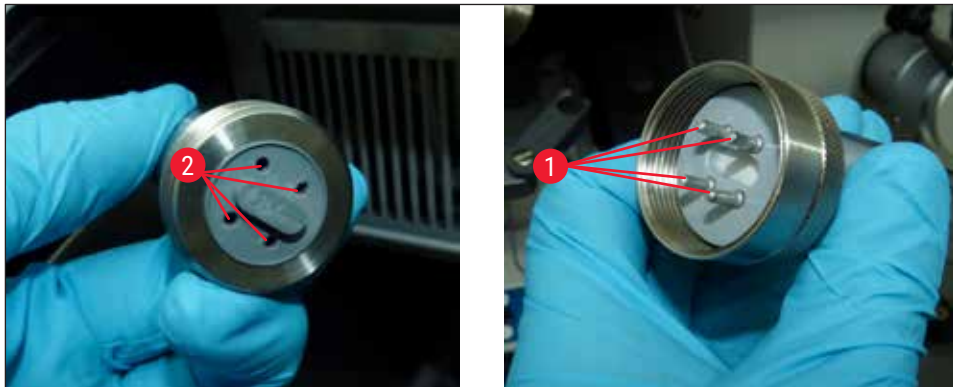

Fig. 62

Removal of the lamp

The UVC lamp (→ Fig. 63-1) is installed in front of the protection screen for chamber illumination (→ Fig. 63-2).

1. Hold the lamp with both hands and carefully pull it out of the clips with a **GENTLE** forwards motion (→ Fig. 63-3).



Fig. 63

2. Detach the metal ring (→ Fig. 64-1) on the holder (→ Fig. 64-2) in the direction of the arrow (→ Fig. 64-3) and carefully pull the lamp out of the holder with your right hand (→ "Fig. 63") (→ "Fig. 64").

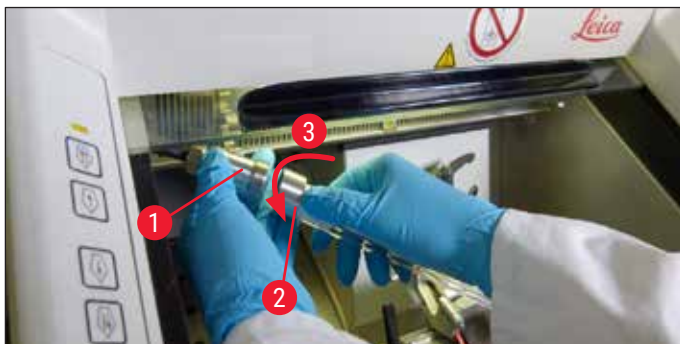

Fig. 64

Installation of the new lamp

1. Carefully slide the metal ring (→ Fig. 65-1) over the lamp from the left (→ "Fig. 65").

**Fig. 65**

2. Push the lamp into the holder on the left side until it engages.
3. Screw the metal ring onto the holder, then hold the lamp with both hands and carefully push it into the clips (→ Fig. 63-3).
4. Reinsert the sliding window.
5. Connect the instrument to the power supply again and switch it on.

**Warning**

- If any metallic mercury is released, handle it carefully and dispose of it properly.
- Dispose of the UVC lamp separately.

9.3.4 Replacing the LED illumination

The LED illumination is designed for maximum life span. In case of damage, please contact Leica customer service to arrange replacement. For further details, see (→ P. 103 – 11. [Warranty and Service](#)).

10. Ordering Information, Components and Consumables

10.1 Ordering information

Description	Order No.
Blade/knife holder and blade/knife holder base	
Blade/knife holder base for CN, CE, premium blade holder	14 0491 47875
Knife holder CN for standard microtome knife	14 0477 42358
Premium blade holder	14 0491 48023
Blade holder CE, high-profile and low-profile	14 0491 47873
Blade holder CE, without clearance angle adjustment	14 0419 33992
Blade holder pressure plate, 22°, for microtome blades	14 0491 48004
Blade holder CE-TC	14 0491 47874
Anti-static kit for blade holder CE, high-profile	14 0800 37740
Anti-static kit for blade holder CE, low-profile	14 0800 37739
Knife support for knife holder CN, for short knives	14 0419 19426
Knife support for knife holder CN, for long knives	14 0419 19427
Disposable blades	
Leica TC-65 disposable blades, 5 pcs.	14 0216 26379
Leica high-profile disposable blades, Type 818, 1 pack of 50	14 0358 38926
Leica high-profile disposable blades, Type 818, 10 packs of 50	14 0358 38383
Leica low-profile disposable blades, Type 819, 1 pack of 50	14 0358 38925
Leica low-profile disposable blades, Type 819, 10 packs of 50	14 0358 38382
Reusable knives	
Knife, 16 cm length, profile c	14 0216 07100
Knife, 16 cm carbide metal blade, profile c	14 0216 04206
Knife, 16 cm length, profile d	14 0216 07132
Knife, 16 cm carbide metal blade, profile d	14 0216 04813
Variable knife case for 1 to 2 knives from 10 to 16 cm in length	14 0213 11140
Dr. Peters cryoembedding system	
Intended use: enables accurate orientation of the tissue samples.	
Case with cryoembedding system	14 0201 40670
Cryoembedding system	14 0201 39115
Embedding well bar set with small recesses, 18 mm	14 0201 39116
Embedding well bar set with medium-sized recesses, 24 mm	14 0201 39117
Embedding well bar set with large recesses, 30 mm	14 0201 39118
Freezing stage/heat extractor set, elevated	14 0201 39119
Embedding well bar, 4 x 18 mm	14 0201 39120
Embedding well bar, 4 x 24 mm	14 0201 39121
Embedding well bar, 3 x 30 mm	14 0201 39122
Specimen stage, rectangular, 28 mm	14 0201 39123

Description	Order No.
Specimen stage, rectangular, 36 mm	14 0201 39124
Heat extractor	14 0201 39125
Container for specimen stages	14 0201 39126
Dispensing slides for Dr. Peters' cryoembedding system, pack of 8	14 0201 39127
Components and consumables	
Intended use: Enables manual staining of cryosections.	
Easy Dip staining container, white, 6 pcs. per package	14 0712 40150
Easy Dip staining container, pink, 6 pcs. per package	14 0712 40151
Easy Dip staining container, green, 6 pcs. per package	14 0712 40152
Easy Dip staining container, yellow, 6 pcs. per package	14 0712 40153
Easy Dip staining container, blue, 6 pcs. per package	14 0712 40154
Easy Dip specimen slide holder, gray, 6 pcs. per package	14 0712 40161
Blue O-ring, for color marking, 20 mm and 30 mm, 10 pcs.	14 0477 43247
Red O-ring, for color marking, 20 mm and 30 mm, 10 pcs.	14 0477 43248
Blue O-ring, for color marking, 40 mm, 10 pcs.	14 0477 43249
Red O-ring, for color marking, 40 mm, 10 pcs.	14 0477 43250
Blue O-ring, for color marking, 55 mm, 10 pcs.	14 0477 43251
Red O-ring, for color marking, 55 mm, 10 pcs.	14 0477 43252
Toolset for cryostats	14 0436 43463
Specimen disc, 20 mm	14 0370 08636
Specimen disc, 25 mm	14 0416 19275
Specimen disc, 30 mm	14 0370 08587
Specimen disc, 40 mm	14 0370 08637
Specimen disc, 55 mm	14 0419 26491
Specimen disc, 50 x 80 mm	14 0419 26750
Intended use: speeds up the process of freezing tissue samples.	
Heat extractor – stationary, assembly	14 0471 30792
Parking station	14 0471 30793
Heat extractor - mobile	14 0443 26836
Transfer block for specimen discs, small (holder for specimen discs)	14 0491 47787
Transfer block for specimen discs, large (holder for specimen discs)	14 0491 47786
Intended use: helps warm up specimen; if too cold, remove specimen from specimen disc.	
Thermal block	14 0398 18542
Miles adapter, for TissueTek specimen discs	14 0436 26747
Plug adapter set EU-UK	14 0411 45349
Shelf, movable, assembly	14 0491 46750
Consumables	
Add-on kit: Swing arm with anti-roll guide system	14 0419 35693
Anti-roll guide system CE, glass - 70 mm, 100 µm spacer for 5 - 50 µm	14 0419 33980

Description	Order No.
Anti-roll guide system CE, glass - 70 mm, 50 µm spacer for up to 4 µm	14 0419 37258
Anti-roll guide system CE, glass - 70 mm, 150 µm spacer for over 50 µm	14 0419 37260
Anti-roll guide system for knife holder CN, for 5 µm - 50 µm	14 0419 33981
Glass insert, glare-reducing, 70 mm wide	14 0477 42497
Glass insert - 50 mm	14 0419 33816
FSC22 tissue freezing medium (9 x 118 ml), clear ¹	380 1480
FSC22 tissue freezing medium (9x118 ml), blue ¹	380 1481
Tissue freezing medium, 125 ml	14 0201 08926
Cryo oil, 250 ml	14 0336 06100
Safety gloves, cut-resistant, size S	14 0340 40859
Safety gloves, cut-resistant, size M	14 0340 29011
UVC fluorescent tube, 2-pin	14 0471 40422
UVC fluorescent tube, 4-pin	14 0471 57384

¹ Product may not be available in your country. Please contact your local distributor.



Note

Leica blade holders are optimized for use with Leica Biosystems disposable blades with the blade dimensions for low-profile blades of: L x H x W (mm) 80 +/-0.05 x 8 +/-0.1 x 0.254 +/-0.008 and blade dimensions for high-profile blades of: L x H x W (mm) 80 +/-0.05 x 14 +/-0.15 x 0.317 +/-0.005.

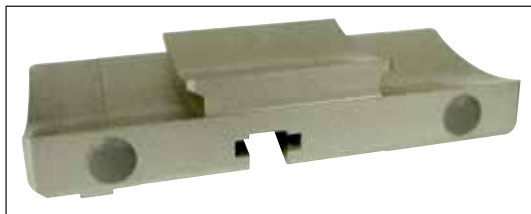

Fig. 66

Knife/blade holder base,

for knife holder CN, blade holder CE, CE-TC, premium blade holder

Order No. 14 0491 47875



Fig. 67

Premium blade holder, assembly,

for high-profile and low-profile blades, with lateral movement, glass anti-roll guide and palm rest

Order No. 14 0491 48023



Fig. 68

Knife holder CN,

for standard microtome knives or magnetic blade rails.

Clearance angle adjustment and knife height adjustment.

Backrests for long and short knives.

Anti-roll guide and adjustable safety guard.

Order No. 14 0477 42358



Fig. 69

Blade holder CE,

universal (high-profile and low-profile disposable blades) with lateral movement and glass anti-roll guide.

Adjustable clearance angle.

Order No. 14 0491 47873

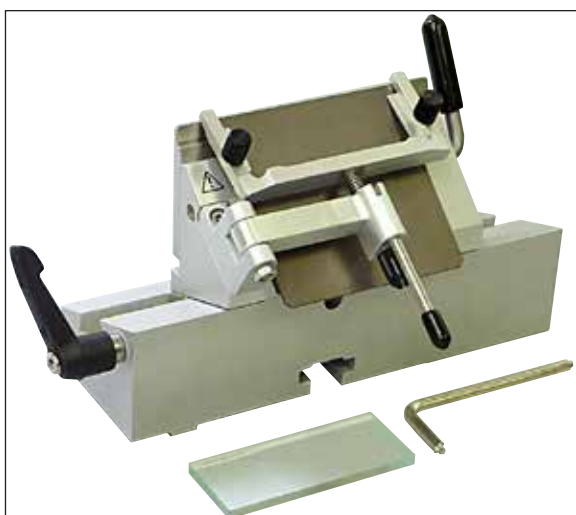

Fig. 70

Blade holder CE,

for low-profile disposable blades, **WITHOUT** clearance angle adjustment, including blade/knife holder base and pressure plates.

Order No. 14 0419 33992



Fig. 71

Blade holder CE-TC,

for tungsten carbide disposable blades.
Particularly suitable for sectioning harder materials, such as tissue, bone or cartilage.

Order No. 14 0491 47874



Fig. 72

Blade holder pressure plate, 22°,

for high-profile microtome blades.

Order No. 14 0491 48004



Fig. 73

Anti-static kit for blade holder CE, high-profile

Order No. 14 0800 37740

Anti-static kit for blade holder CE, low-profile

Order No. 14 0800 37739



Fig. 74

Backrest for knife holder CN,

for short knives

Order No. 14 0419 19426

Backrest for knife holder CN,

for long knives

Order No. 14 0419 19427



Fig. 75

Disposable blades Leica TC-65,

Leica TC-65 microtome, disposable blade system for sectioning hard specimen materials.

The Leica TC-65 tungsten carbide disposable blades were specially developed for the requirements in labs where hard, blunt materials are routinely sectioned.

The one-of-a-kind fine-grain carbide metal guarantees sections to approx. 2 μm . The blades are fully recyclable.

Length: 65 mm, thickness: 1 mm, Height: 11 mm

Leica TC-65 tungsten carbide disposable blades.

Pack of 5.

Order No. 14 0216 26379



Fig. 76

Leica high-profile disposable blades, Type 818

80 x 14 x 0.317 mm

1 pack of 50 pcs.

Order No. 14 0358 38926

10 packs of 50 pcs.

Order No. 14 0358 38383



Fig. 77

Leica low-profile disposable blades, Type 819

80 x 8 x 0.25 mm

1 pack of 50 pcs.

Order No. 14 0358 38925

10 packs of 50 pcs.

Order No. 14 0358 38382



Fig. 78

Knife, 16 cm, steel, profile c,

(flat on both sides, for wax and frozen sections).
Serial number of the knife (→ Fig. 78-1)

Note: including knife case 14 0213 11140

Order No.

14 0216 07100



Fig. 79

Knife, 16 cm, tungsten carbide, profile c,

Note: including knife case 14 0213 11140

Order No.

14 0216 04206

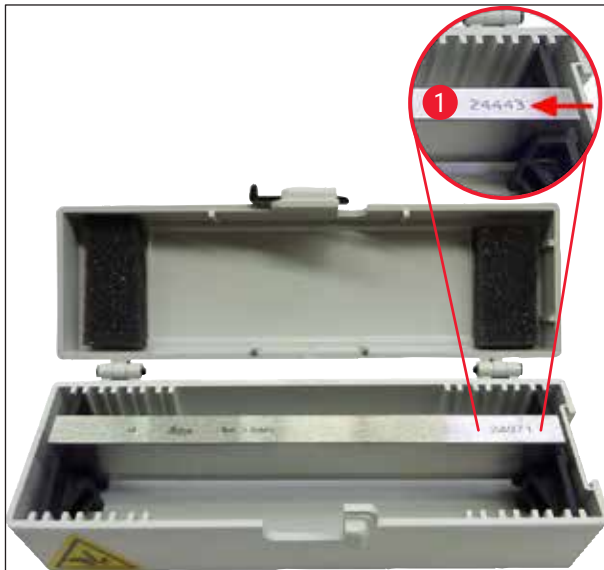

Fig. 80

Knife, 16 cm, steel, profile d,

Note: including knife case 14 0213 11140

Order No. 14 0216 07132

Knife, 16 cm, tungsten carbide, profile d,

Note: including knife case 14 0213 11140

Serial number of the knife (→ Fig. 80-1)

Order No. 14 0216 04813



Fig. 81

Variable knife case,

For 1 to 2 knives from 10 to 16 cm in length

Order No. 14 0213 11140



Fig. 82

Case with cryoembedding system includes:

- 3 embedding well bars with recesses, in three sizes: 18 mm, 24 mm, 30 mm
- 6 specimen stages, small
- 4 specimen stages, large
- 4 heat extractors
- 1 container for specimen stages
- 16 dispensing slides
- 1 sectioning board/freezing stage
- 1 heat extractor, elevated
- 1 embedding forceps, angled

Order No.

14 0201 40670

Cryoembedding system, assembly

consisting of:

- 3 embedding well bars with recesses in three sizes: 18 mm, 24 mm, 30 mm
- 6 specimen stages, small
- 4 specimen stages, large
- 4 heat extractors
- 1 container for specimen stages
- 16 dispensing slides
- 1 sectioning board/freezing stage
- 1 heat extractor, elevated
- 1 embedding forceps, angled



Fig. 83

Order No.

14 0201 39115



Fig. 84

Embedding well bar set

with small recesses consisting of:

- 1 embedding well bar, 18 mm recesses
- 4 specimen stages, small
- 2 heat extractors
- 8 dispensing slides

Order No. 14 0201 39116**Embedding well bar set**

with medium-sized recesses consisting of:

- 1 embedding well bar, 24 mm recesses
- 4 specimen stages, small
- 2 heat extractors
- 8 dispensing slides

Order No. 14 0201 39117**Embedding well bar set**

with large recesses consisting of:

- 1 embedding well bar, 30 mm recesses
- 4 specimen stages, large
- 2 heat extractors
- 8 dispensing slides

Order No. 14 0201 39118**Set of freezing stage/heat extractor,**

elevated, consisting of:

- 1 forceps, epoxy-coated
- 1 putty knife
- Extra elevating bars

Order No. 14 0201 39119

Fig. 85



Fig. 86

Embedding well bar

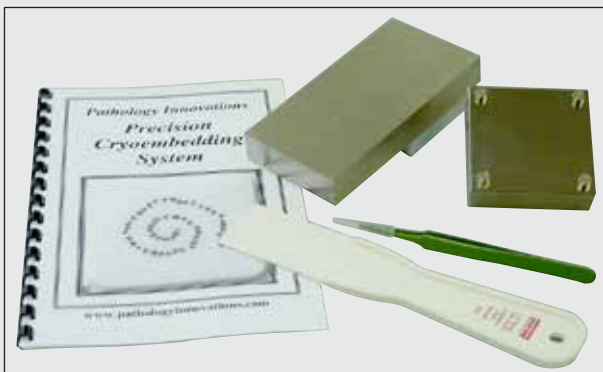
Height: 25.4 mm
with 4 recesses, size 18 mm, stainless steel

Order No. 14 0201 39120

Height: 25.4 mm
with 4 recesses, size 24 mm, stainless steel

Order No. 14 0201 39121

Height: 25.4 mm
with 3 recesses, size 30 mm, stainless steel

Order No. 14 0201 39122

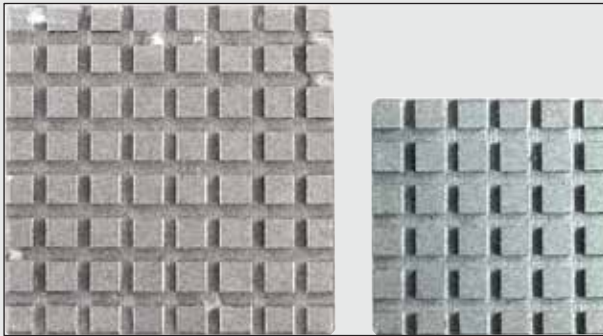

Fig. 87

Specimen stage,

rectangular, stainless steel, small - 28 mm
Pack of 1.

Order No. 14 0201 39123

Specimen stage,

rectangular, stainless steel, size - 36 mm
Pack of 1.

Order No. 14 0201 39124

Heat extractor

Order No. 14 0201 39125



Fig. 88



Fig. 89

Container for specimen stages

Order No. 14 0201 39126

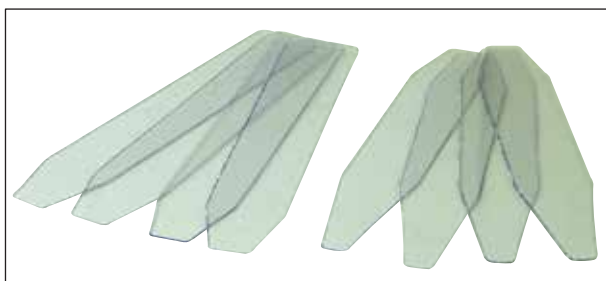

Fig. 90

Dispensing slides for Dr. Peters' cryoembedding system

Pack of 8.

Order No. 14 0201 39127

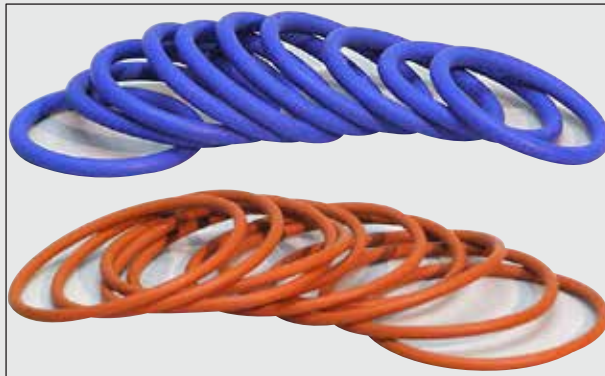

Fig. 91

Blue O-ring,

for color-marking the 20 mm and 30 mm specimen discs, pack of 10

Order No. 14 0477 43247

Red O-ring,

for color-marking the 20 mm and 30 mm specimen discs, pack of 10

Order No. 14 0477 43248

Blue O-ring,

for color-marking the 40 mm specimen discs, pack of 10

Order No. 14 0477 43249

Red O-ring,

for color-marking the 40 mm specimen discs, pack of 10

Order No. 14 0477 43250

Blue O-ring,

for color-marking the 55 mm specimen discs, pack of 10

Order No. 14 0477 43251

Red O-ring,

for color-marking the 55 mm specimen discs, pack of 10

Order No. 14 0477 43252

Toolset for cryostats,

consisting of:

- 1 brush, narrow 14 0183 28642
- 1 Leica brush with magnet 14 0183 40426
- 1 Hexagon key with handle, No. 5 14 0194 04760
- 1 Hexagon key, No. 2.5 14 0222 04137
- 1 Hexagon key, No. 3.0 14 0222 04138
- 1 Hexagon key, No. 4.0 14 0222 04139
- 1 Hexagon key, No. 5.0 14 0222 04140
- 1 Hexagon key, No. 6.0 14 0222 04141
- 1 Hexagon key, No. 1.5 14 0222 10050
- 1 Hexagon key, ball-cage, No. 4 14 0222 32131
- 1 double-head wrench, 16/13 14 0330 18595



Fig. 92

Order No. 14 0436 43463



Fig. 93

Easy Dip, specimen slide holder,
for 12 specimen slides, gray
Pack of 6

Order No. 14 0712 40161



Fig. 94

Easy Dip, staining container

Color: white

Pack of 6

Order No. 14 0712 40150

Color: pink

Pack of 6

Order No. 14 0712 40151

Color: green

Pack of 6

Order No. 14 0712 40152

Color: Yellow

Pack of 6

Order No. 14 0712 40153

Color: Blue

Pack of 6

Order No. 14 0712 40154







	<p>Specimen disc,</p>
 	<p>20 mm Order No. 14 0370 08636</p>
 	<p>25 mm Order No. 14 0416 19275</p>
 	<p>30 mm Order No. 14 0370 08587</p>
 	<p>40 mm Order No. 14 0370 08637</p>
 	<p>55 mm Order No. 14 0419 26491</p>
 	<p>50 x 80 mm Order No. 14 0419 26750</p>
	

Fig. 95

10 Ordering Information, Components and Consumables

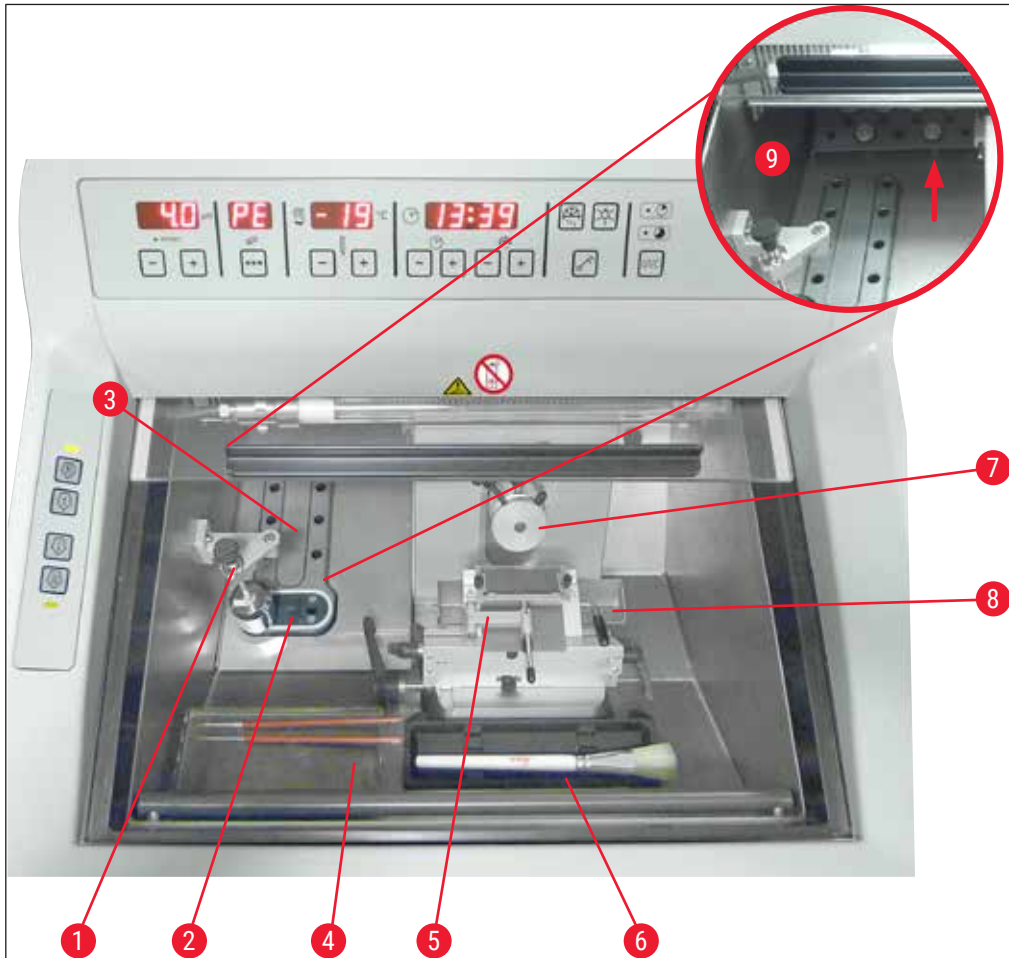

Fig. 96

- | | | | |
|---|--|---|---------------------------|
| 1 | Heat extractor, stationary (optional) | 6 | Brush shelf |
| 2 | Peltier element (with 2 startions) | 7 | Specimen head, orientable |
| 3 | Freeze shelf, 8 positions | 8 | Waste tray |
| 4 | Shelf, movable (optional) | 9 | Storage space |
| 5 | Blade holder CE with anti-roll guide - also functions as a safety guard (optional) | | |



Fig. 97

Transfer block

for specimen discs, large (13 slots)

Order No.

14 0491 47786



Fig. 98

Transfer block

for specimen discs, small (5 slots)

Order No.

14 0491 47787

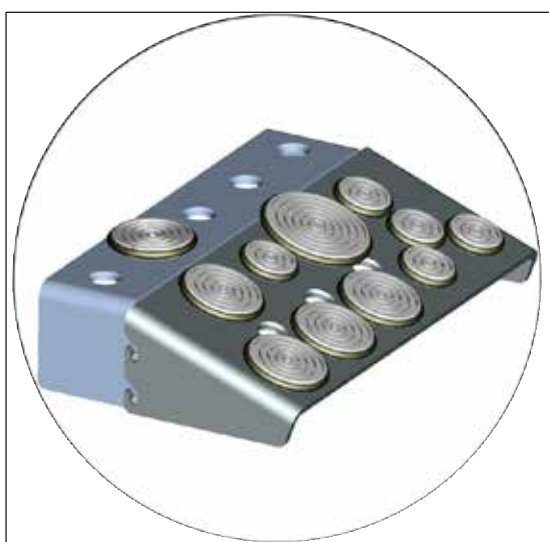

Fig. 99

Large transfer blocks (→ "Fig. 97") and small transfer blocks (→ "Fig. 98") can be combined (→ "Fig. 99").



Fig. 100

Heat extractor

mobile (→ P. 100 – 10.2 Mobile heat extractor - application)

Order No. 14 0443 26836



Fig. 101

Thermal block

for easy removal of frozen tissue from the specimen disc (→ P. 101 – 10.3 Cold extraction - using the Thermal block).

Order No. 14 0398 18542



Fig. 102

Adapter

for Miles Tissue Tek specimen discs.

Order No. 14 0436 26747

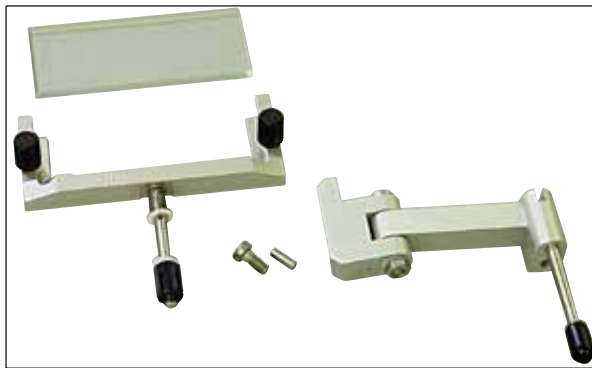

Fig. 103

Add-on kit:

Swing arm with anti-roll guide system

consisting of:

Swing arm

Anti-roll guide system:

- Glass insert 70 mm
- Metal frame for exchangeable glass inserts CE
- 100 µm spacer

Recommended section thickness 5 µm – 50 µm

For blade holder CE:

(14 0491 47873, 14 0419 33992)

Order No.

14 0419 35693

Anti-roll guide system CE

Glass - 70 mm, consisting of:

- Glass insert 70 mm
- Metal frame for exchangeable glass inserts CE
- 100 µm spacer

Recommended section thickness 5 µm – 50 µm

For blade holder CE:

(14 0491 47873, 14 0419 33992)

Order No.

14 0419 33980



Fig. 104

Anti-roll guide system CE

Glass - 70 mm, for special application, consisting of:

- Glass insert 70 mm
- Metal frame for exchangeable glass inserts CE
- 50 µm spacer

Recommended section thickness up to 4 µm

For blade holder CE:

(14 0491 47873, 14 0419 33992)

Order No.

14 0419 37258

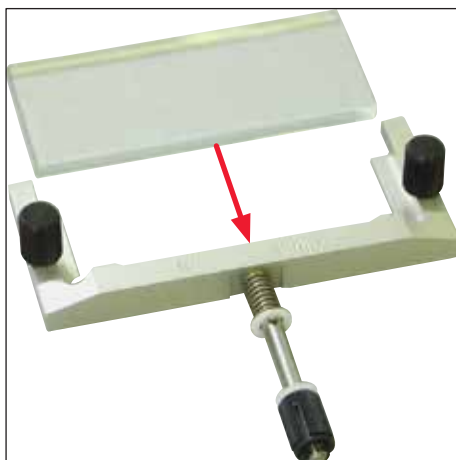

Fig. 105

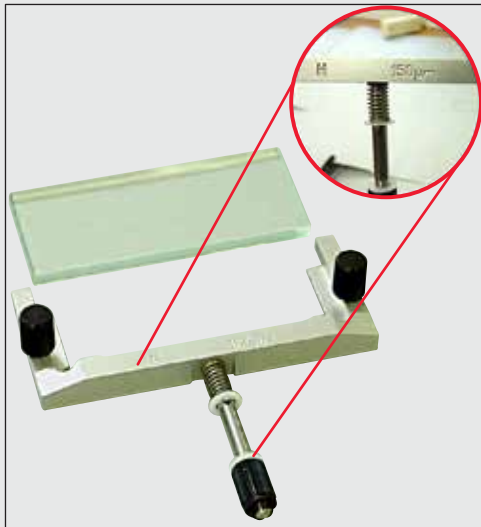

Fig. 106

Anti-roll guide system CE

Glass - 70 mm, for special application, consisting of:

- Glass insert 70 mm
- Metal frame for exchangeable glass inserts CE
- 150 µm spacer

Recommended section thickness over 50 µm

For blade holder CE:

(14 0491 47873, 14 0419 33992)

Order No. 14 0419 37260



Fig. 107

Anti-roll guide system

for knife holder CN, glass – 50 mm, consisting of:

- Glass insert 50 mm
 - Metal frame for exchangeable glass inserts CN
- Recommended section thickness 5 µm – 50 µm

Order No. 14 0419 33981



Fig. 108

Glass insert

glare-reducing, 70 mm wide

Spare glass for anti-roll guide systems CE-BB:

(14 0477 42491, 14 0477 42492, 14 0477 42493)

for blade holder CE-BB (14 0477 43005)

Order No. 14 0477 42497

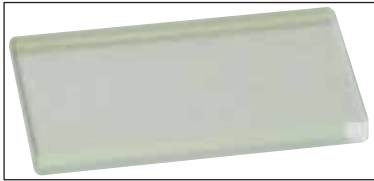

Fig. 109

Glass insert

50 mm

For knife holder CN (14 0477 42358)

Order No.

14 0419 33816



Fig. 110

Water-soluble embedding medium FSC 22,

for cryosectioning, FSC 22 is available in clear or in light blue for better visualization of small specimens

Clear, 9 x 118 ml

Order No.

380 1480

Blue, 9 x 118 ml

Order No.

380 1481



Both media may not be available in your country. Please contact your local distributor.

Embedding medium

for cryosectioning

Tissue Freezing Medium, 125 ml

Order No.

14 0201 08926



Fig. 111



Fig. 112

Cryo oil

250 ml bottle

Order No.**14 0336 06100**

Fig. 113

Cut-resistant safety gloves

1 pair, size S

Order No.**14 0340 40859****Cut-resistant safety gloves**

1 pair, size M

Order No.**14 0340 29011**



Fig. 114

Heat extractor

stationary, assembly

Order No. 14 0471 30792

Low-temperature buffer for heat extractor
(parking station) (→ Fig. 114-1)

Order No. 14 0471 30793



Fig. 115

UVC fluorescent tube 2-pin

Order No. 14 0471 40422

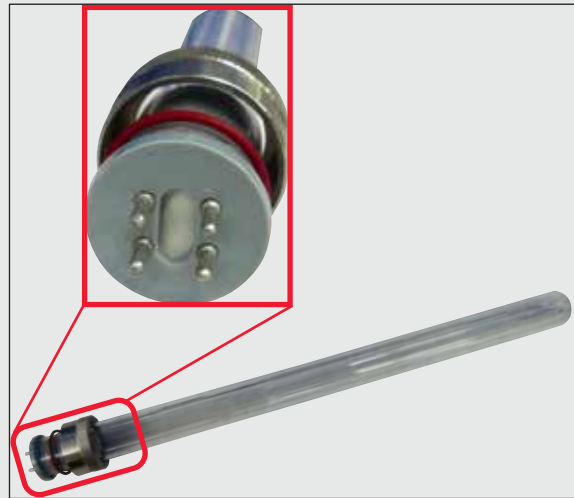

Fig. 116

UVC fluorescent tube 4-pin

Order No. 14 0471 57384



Fig. 117

Storage system, movable

for installation in the front part of the cryostat for cooled storage of preparation aids.

Order No. 14 0491 46750

10.2 Mobile heat extractor - application

Specimen freezing with the freezing shelf can be accelerated by the additional use of a heat extractor.

1. Store the heat extractor in the cryochamber.
2. Hold it on the specimen surface to accelerate freezing.
3. Take it away once the specimen is entirely frozen.



Note

Recommendation:

It is recommended to precool the heat extractor in liquid nitrogen or other refrigerant.



Warning

Caution! There is a risk of injury due to freezer burn!

10.3 Cold extraction - using the Thermal block

The thermal block (→ Fig. 118-4) facilitates the removal of the frozen specimen from the specimen disc.



Note

The thermal block is not stored in the cryostat chamber; rather, it is stored outside at room temperature.

1. Place the cap (→ Fig. 118-5) on the required side so that the appropriate location hole for the specimen disc is visible.
2. Fit the pin (→ Fig. 118-2) of the specimen disc (→ Fig. 118-1) into the corresponding hole (→ Fig. 118-3) on the thermal block.
3. After about 20 seconds, the frozen specimen can be removed from the specimen disc with forceps (→ Fig. 118-7).
4. If the cap is too loose, readjust it using the screw (→ Fig. 118-6).



Note

Do not overtighten the screw.

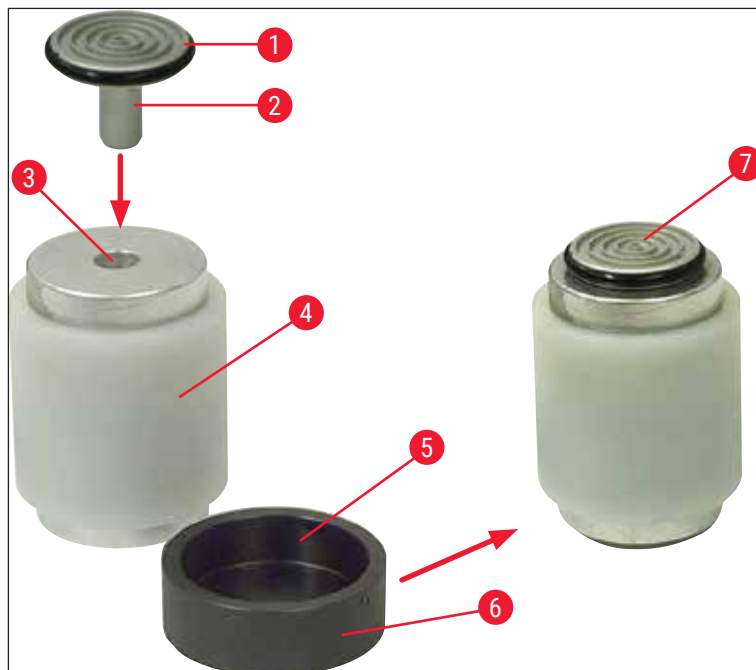

Fig. 118

10 Ordering Information, Components and Consumables

10.4 Stationary heat extractor (optional) - application

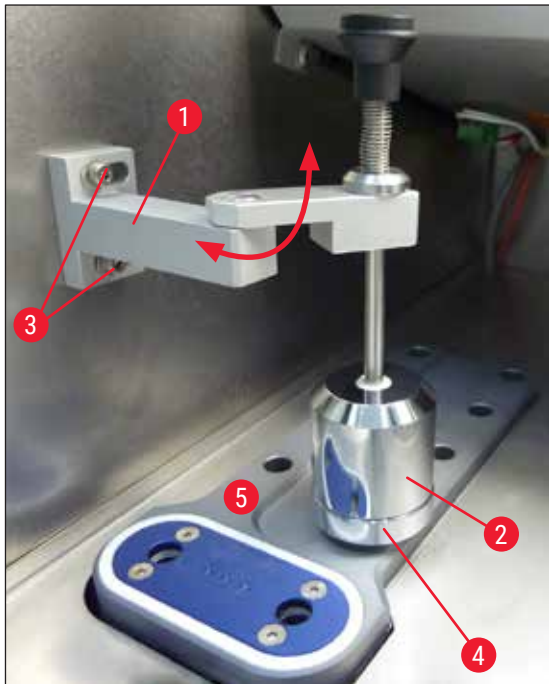

Fig. 119

- Fasten the support (→ Fig. 119-1) of the heat extractor (→ Fig. 119-2) to the left side panel of the cryochamber using two screws at the provided holes (→ Fig. 119-3) and insert the heat extractor.
- Mount parking station (→ Fig. 119-4) into one hole of the quick freezing shelf (→ Fig. 119-5) and rest the heat extractor on it to cool down.
- Move the heat extractor from the parking station and lower it directly onto the surface of the specimen until it is completely frozen.
- After the specimen is frozen, move the heat extractor into resting position at the parking station (→ Fig. 119-4).

10.5 Installing the shelf (movable) (optional)



Fig. 120

- Attach the rod for the shelf to the inner front side of the cryostat housing using the provided screws (→ Fig. 120-1) and the No. 3 Hexagon key, then attach the caps (→ Fig. 120-3). (The rear side of the movable shelf has white plastic screws (→ Fig. 120-2) that prevent the interior of the cryochamber from being scratched.)
- Now hook the movable shelf into the guide bar.

11. Warranty and Service

Warranty

Leica Biosystems Nussloch GmbH guarantees that the contractual product delivered has been subjected to a comprehensive quality control procedure based on the Leica in-house testing standards, and that the product is faultless and complies with all technical specifications and/or agreed characteristics warranted.

The scope of the warranty is based on the content of the concluded agreement. The warranty terms of your Leica sales organization or the organization from which you have purchased the contractual product shall apply exclusively.

Yearly Preventive Maintenance

Leica recommends to conduct a yearly preventive maintenance. This has to be performed by a qualified Leica Service Representative.

Service information

If you are in need of technical customer support or spare parts, please contact your Leica representative or the Leica dealer where you purchased the instrument.

Please provide the following information about the instrument:

- Model name and serial number of the instrument.
- Location of the instrument and name of a contact person.
- Reason for the service call.
- Delivery date.

Decommissioning and disposal

The instrument or parts of the instrument must be disposed of according to existing applicable, local regulations. Dispose of UVC lamp in accordance with the local applicable disposal regulations.

12 Decontamination Certificate

12. Decontamination Certificate

Any product that is to be returned to Leica Biosystems or serviced on site must be properly cleaned and decontaminated. Please find the dedicated template for confirming decontamination by using the search function on our website at www.LeicaBiosystems.com. This template must be used to enter all required data.

If a product is returned, a copy of the completed and signed decontamination certificate must either be enclosed or handed over to a service technician. The user shall be responsible for products that are returned without a completed decontamination certificate or with a missing decontamination certificate. Return shipments that are classified by the company as a potential hazard source will be returned to sender at his/her own expense and risk.

www.LeicaBiosystems.com



Leica Biosystems Nussloch GmbH
Heidelberger Strasse 17 - 19
69226 Nussloch
Germany

Tel.: +49 - (0) 6224 - 143 0
Fax: +49 - (0) 6224 - 143 268
Web: www.LeicaBiosystems.com